

PATHS **2050**

PATHS 2050 - Scenarios towards a carbon-neutral Belgium by 2050

Authors: Juan Correa Laguna, Andrea Moglianesi, Pieter Vingerhoets, Wouter Nijs, Pieter Lodewijks

Date: 6 July 2023



Empowered by KU Leuven, VITO, imec & UHasselt

Table of Contents

Table of Contents	2
1. Introduction and scope	4
2. Model framework	6
2.1. The TIMES model	6
2.2. Structure of representative days	7
3. Scenario description	8
3.1. Common assumptions for all scenarios	8
3.2. Central Scenario	8
3.3. Electrification Scenario	9
3.4. Clean Molecules Scenario	9
3.5. Scenarios overview	10
4. Demand sectors	12
4.1. Macroeconomic assumptions	12
4.2. Industry	12
4.2.1. Steel sector	14
4.2.2. Chemical sector	15
4.2.3. Non-metallic minerals	19
4.2.4. Non-ferrous metals	23
4.2.5. Food and beverages	24
4.2.6. Pulp and paper	24
4.2.7. Other industries, not elsewhere specified energy consumption and non-energy demand	24
4.3. Transport	25
4.4. Residential	27
4.5. Commercial	29
4.6. Agriculture	30
5. Supply and transformation sectors	31
5.1. Fuel and material prices	31
5.2. Maximum resource availability	32
5.3. Electricity network assumptions	32
5.4. Molecule supply sector	34
5.4.1. Refineries	34
5.4.2. Molecules	34
6. Main scenarios' results	36
6.1. Power sector	36
6.1.1. Capacity and generation	36
6.1.2. Electricity generation and demand profiles	38
6.1.2.1. Generation profile during a typical summer day in 2050	38
6.1.2.2. Demand profile during a typical summer day in 2050	39
6.1.2.3. Generation profile during a typical winter day in 2050	40
6.1.2.4. Demand profile during a typical winter day in 2050	41
6.1.3. CO ₂ emissions	42
6.1.4. Annual costs	42
6.1.5. Electricity generation costs	43
6.2. Industrial sector	43
6.2.1. Final energy use	43
6.2.2. CO ₂ emissions	45
6.2.3. Annual costs	46
6.3. Residential and commercial sectors	46
6.3.1. Final energy use	46
6.3.2. CO ₂ emissions	47
6.3.3. Annual costs	48
6.4. Transport sector	48
6.4.1. Final energy use	48
6.4.2. CO ₂ emissions	49
6.4.3. Annual costs	50
6.5. Hydrogen	50
6.5.1. Hydrogen supply and demand	50
6.5.1.1. Hydrogen supply	50
6.5.1.2. Hydrogen demand	51

7. Sensitivity cases' results	52
7.1. Impact of sensitivity cases on the energy system	52
7.2. Annual costs by sensitivity case	56
7.3. Key takeaways from sensitivity cases	56
Conclusion and discussion	58
Annex A. Main techno-economic assumptions	60

This work was supported by FEBELIEC VZW.

The underlying model exercise was developed on the basis of the Belgian Energy Transition Fund projects EPOC 2030-2050, BREGILAB and PROCURA, Organised by the FPS economy.

The opinions expressed in this publication are those of the authors.

1. Introduction and scope

The EU aims to be climate neutral by 2050 – an economy with net zero greenhouse gas emissions. This objective lies at the heart of the European Green Deal, and is in line with the EU's commitment to global climate action under the Paris Agreement. All parts of society and all economic sectors will play a role – from the power sector to industry, mobility, buildings, agriculture and forestry. This transition will impose stress on the energy system, as society moves towards new and emerging technologies to meet service and product demands (e.g., space heating, mobility, steel, cement). More recently, the recovery from the COVID-19 crisis and the war in Ukraine have caused a peak in fossil fuel prices, mainly natural gas. As a response, the European Commission published the RepowerEU plan, increasing the ambitions for green hydrogen production and aiming for a fast reduction of fossil fuel dependency by 2030¹.

Belgium is one of the most densely populated countries in Europe and houses large industrial clusters. It has an average per capita primary energy consumption of 64.9 MWh/person². Compared with Germany (44.2 TWh/person), France (41.9 MWh/person) and Denmark (33.9 MWh/person), Belgium requires more energy – not only for its buildings, but mostly for its industry and transport sectors, which together account for roughly 70% of total final energy and non-energy consumption. When a comparison is made based on land energy intensity³, Belgium has an intensity of 18.4 TWh/km², which is almost twice as much as in Germany, and four times higher than in France and Denmark. Therefore, Belgium is positioned as one of the most energy-intense regions in Europe, and a giant transformation of its energy system will be required to support a carbon-neutral economy.

At the same time, the geographical location of Belgium reduces its access to energy resources such as onshore wind. Moreover, solar capacity factors are lower than in the Mediterranean regions. Nevertheless, the same geographical location provides Belgium with a strategic position to serve as an energy-carriers import hub for Europe. This is the case today for petroleum products⁴ and natural gas (i.e., gas pipelines and LNG) – around 80 bcm of natural gas transit through Belgium each year⁵.

Innovations in energy and industry open up more alternatives to reduce carbon intensity in several applications, which also increases the uncertainty of the future energy landscape. In general, gaining insight into possible future solutions results in great value for decision makers today. This is why FEBELIEC VZW wanted to obtain deeper insights into the effectiveness, efficiency and costs of potential innovation pathways to achieving carbon-neutrality in Belgium. This transition towards a carbon-neutral economy is a complex interplay between sectors, technologies and energy carriers. Therefore, we explore what the future energy system could look like when decisions are based on system cost minimization, with a holistic view using a highly detailed energy system model. Thus, this study is unique in its kind by pioneering on:

- **An integrated system approach including all sectors:** this study not only includes sector-specific technical solutions, but equally explores investment pathways in an integrated energy system approach, in which full system cost efficiency is the driving factor. All energy carriers are part of the modelling exercise.
- **A high level of industrial process detail:** allowing for insights into investment pathways towards carbon-neutrality for specific industries.
- **Working in tandem:** a close collaboration between industry and researchers has been set up, allowing the researchers to build upon industrial insights and needs.

For this complete system analysis of the Belgian energy and industry system (including feedstock), the Belgian TIMES model (TIMES-BE) was used. The TIMES model is a well-known energy system model which is further developed in a community of research teams around the world⁶. Cost efficiency is the driving force in the scenario setup of this techno-economic modelling framework. Given the parameter and boundary assumptions, the model will always give the cost-optimal pathway solution to reach a net zero energy system in 2050. The 2022 version of the EnergyVille TIMES-BE model is the result of years of development within the framework of recent research projects, most of which were funded within the Energy Transition Fund of the Belgian FOD Economie. Within the EPOC, BREGILAB and PROCURA projects, the following model functionalities were implemented:

- EPOC:**
- Detailing the industrial processes in Belgium with their technical potential to evolve to net zero by 2050.
 - Improving the representation of import/export of electricity in Europe and towards Belgium.

- BREGILAB:**
- Detailing the technical potential of onshore wind and PV per province in Belgium.
 - Improving flexibility options to accommodate large volumes of intermittent renewable electricity production: smart charging of electric vehicles, battery storage, heat pumps, water buffers, and so on.

- PROCURA:**
- Detailing the production of clean molecules such as hydrogen and derivatives in Belgium: blue hydrogen (from natural gas and carbon capture and storage) and green hydrogen.
 - Including import of molecules in Belgium through pipelines or by ships.

This report details investment pathways to reach the 2050 climate targets, including a detailed description of the model setup, the scenarios and assumptions. The complete results of this study can also be found on the online [PATHS 2050 Platform](#), where the graphs are presented in an interactive way.

In Section 2, this report describes the TIMES modelling framework and more specific the TIMES-BE model. In Section 3, more background on the storylines and scenarios is presented. In Section 4, for each sector (i.e., industry, transport, residential), we describe in more detail the demands or production rate, the structure of the base year, the processes implemented in TIMES-BE, as well as the main macroeconomic assumptions. In Section 5, we briefly explain the structure of the power generation sector and the power grid, as well as refineries and the future production of molecules. This chapter includes energy carriers' price projections and availability of resources. In Section 6, the results of the main scenarios are presented and discussed. Then, Section 7 presents the results of sensitivity cases derived from the three main scenarios, exploring the uncertainty of certain assumptions in the model. Finally, in the Conclusion Section, we discuss the results and provide conclusions and policy implications. A summary of assumptions and model parameters is given in *Annex A. Main techno-economic assumptions*.

1 European Commission, The RepowerEU plan, https://commission.europa.eu/publications/key-documents-repowerEU_en, 2022.

2 <https://ourworldindata.org/grapher/per-capita-energy-use?tab=table&time=earliest.2019®ion=Europe>

3 Primary energy consumption divided by country area.

4 <https://www.iea.org/articles/belgium-oil-security-policy>

5 An Overview of LNG Import Terminals in Europe (pg8), King & Spalding, 2018. https://www.kslaw.com/attachments/000/006/010/original/LNG_in_Europe_2018_-_An_Overview_of_LNG_Import_Terminals_in_Europe.pdf?1530031152

6 TIMES - IEA-ETSAP Optimisation Modeling Documentation: <https://iea-etsap.org/index.php/documentation>

2. Model framework

In the following section, we describe the TIMES modelling framework and the selection of temporal resolution used in TIMES-BE.

2.1 The TIMES model

TIMES, as defined on its website⁷, is a modelling framework used to model energy systems varying the spatial and temporal resolution (e.g., regions, countries, hours, seasons, years), which allows for the development of both top-down and bottom-up models. The TIMES model is developed as part of the IEA-ETSAP's methodology for energy scenarios to conduct in-depth energy and environmental analyses⁸.

A simplified overview of the TIMES modelling framework is given in Figure 1. At the right-hand side of the figure, the demand for services is indicated in green. These are the products and services needed by society at any point in the energy transition: industrial products (such as steel, cement, chemicals, etc.), light and heating in residential, commercial and agriculture sectors, person and freight transport, and so on.

These demand services are an external assumption to the model setup, and will be discussed in more detail in Section 4. In the middle of Figure 1, all the processes which can deliver those final demand services are described. For every process in the model, one or several emission reduction technologies are included in the model. For instance, for the production of steel, the blast furnace and blast oxygen furnace are modelled, today using coal. As an alternative to this process, the reduction of iron oxide with hydrogen is modelled, as well as the possible use of carbon capture and storage or utilization. The model may, then, invest in either one of the climate-friendly technologies when commercially viable due to increasing CO₂ prices or climate ambitions. As a second example, heavy road transport is today largely diesel-fuelled, and the model may switch to electrification, biofuels or hydrogen if and when appropriate.

Between processes, the exchange of energy carriers and feedstock is needed, such as electricity, heating, fossil fuels and synthetic fuels such as hydrogen, ammonia, methanol, etc. The assumptions on fuel prices are detailed in Section 5. Not all energy can be generated locally in Belgium, and the import of electricity, fuels and other energy carriers are taken into account.

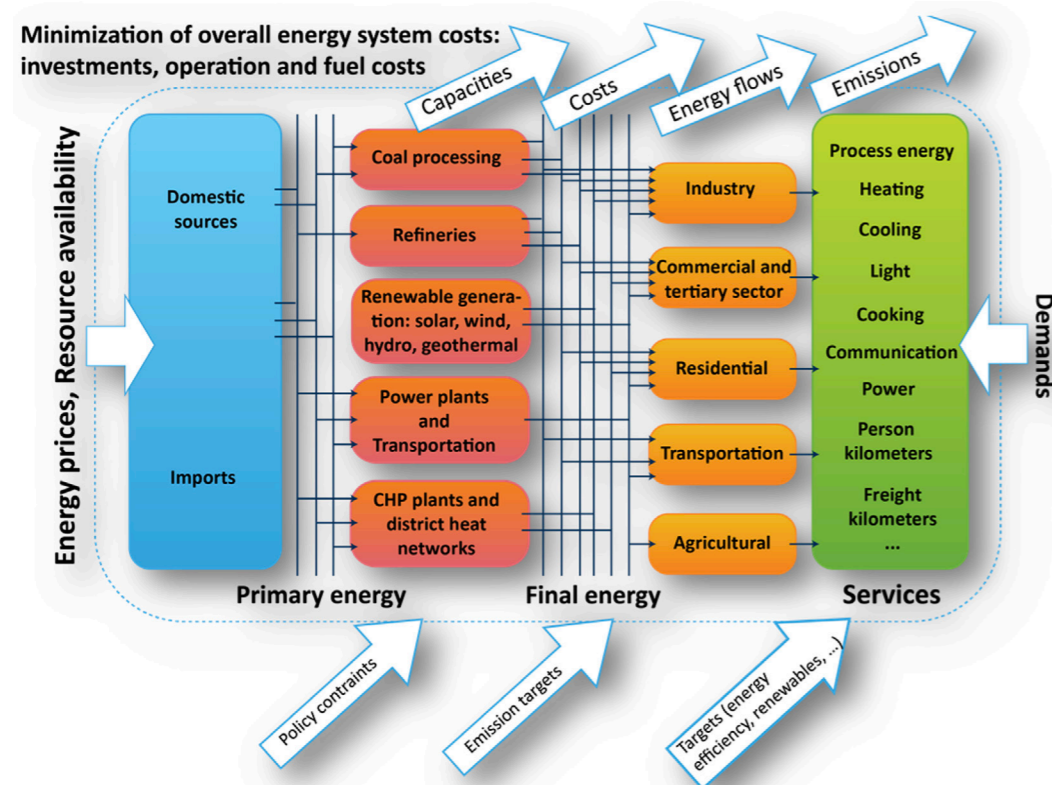

Figure 1. Schematic of TIMES inputs and outputs; EnergyVille adapted from Remme et al., 2001 (ETSAP, 2005)

The model then considers all processes and energy carriers to deliver the demand services which are needed by society, and performs a cost optimisation over the full-time horizon. Every process has an associated investment cost, operational costs, fuel cost (e.g., the gas price for gas power plants), efficiency, etc. This information is used to perform the large cost optimisation which spans all sectors and energy carriers for the entire time period.

⁷ <https://iea-etsap.org/index.php/etsap-tools/model-generators/times>
⁸ (Loulou et al., 2004), (Loulou et al., 2005)

TIMES is able to represent the full value chain from the import or mining of energy and material resources, up to meeting final demands, either in terms of energy or products (e.g., ammonia, glass, space heating, lighting). The modelling framework uses what is called commodities to represent the flow of energy carriers and materials between processes. These processes can represent transformation processes such as energy transformation processes (including electricity production, coke ovens, transmission and distribution equipment, biofuels production) or final energy-consuming processes (including vehicles, industrial processes, light bulbs, refrigerators, boilers, air-cooling, etc.). The processes, commodities and commodities flows are used to build the mathematical representation of the energy system – the Linear Program (LP) – which is then needed to optimize. The optimisation includes the constraints defined by physics such as the balance between electricity demand and electricity generation in each period, as well as user-defined constraints such as the maximum capacity of certain technologies, annual growth and emissions targets. Finally, the results of the model and the defined scenarios provide detailed information such as installed capacity, energy and material flows, marginal production cost, CO₂ emissions, investments and O&M costs needed to meet the different demands in a cost-optimal manner (see Figure 1). The TIMES-BE model has been in the course of development by VITO - EnergyVille for several years, incorporating insights and good practices from the international TIMES-ETSAP modelling community.

2.2 Structure of representative days

The model setup described above yields a linear optimisation problem of millions of equations. At every time step, the requirement that the energy supply fulfils the demand translates into constraints of the linear optimisation problem, increasing calculation time. Thus, including all energy vectors, all demand sectors and all transformation processes, makes it – from the perspective of calculation time – unfeasible to generate hourly results for every year until 2050.

Therefore, the model works with 10 representative days, which are chosen based on a clustering algorithm⁹. The time to which demand and supply are matched is on a 2-hourly basis. Earlier studies have indicated that the results of investment model runs are very similar and consistent between hourly basis and 2-hourly basis, reducing the converging time of the LP without largely affecting the optimisation results¹⁰.

⁹ Selecting representative days for investment planning models, K. Poncelet, et al. 2015.
https://www.mech.kuleuven.be/en/tme/research/energy_environment/Pdf/wpen201510.pdf

¹⁰ Impact of the level of temporal and operational detail in energy-system planning models, K. Poncelet, et al. 2016.
<https://doi.org/10.1016/j.apenergy.2015.10.100>

3. Scenario description

In this chapter, we present the scenarios taken along in the study. Scenarios are defined as a set of assumptions to capture the uncertainties in the future energy system. These uncertainties may, for instance, be related to fuel prices, import constraints, geospatial potential of energy technologies, or innovations affecting future costs. Scenario results, as described in Section 6, should not be seen as predictions of the future, but rather as a 'what if' analysis. Under a certain set of scenario assumptions, the results identify the techno-economic optimum.

In this chapter, the main differences between the scenarios are briefly outlined. More detail is offered in Section 4 for the demand sectors, and Section 5 for the supply and transformation sectors.

To assess the future landscape of the Belgian energy system, and in particular the role of the industry in the transition toward a carbon-neutral economy, we define a Central Scenario from which two additional scenarios and ten sensitivity cases are derived. The differences across these scenarios are described in Table 3.

3.1 Common assumptions for all scenarios

For a detailed explanation of the assumptions of the scenarios and a full list of parameters, we refer to Sections 4 and 5. Below we briefly summarize the most important elements:

- All scenarios are designed to have the Belgian energy system in 2050 reach net zero CO₂ emissions. In addition, there is a CO₂ price increasing from today's levels to 350 €/ton CO₂ in 2050. This value is in line with European Fit for 55 modelling exercises. The CO₂ price is necessary, as otherwise the model only invests in climate-friendly technologies at the end of the energy transition.
- Under all scenarios, industrial production levels in Belgium are assumed to stay as they are today, with planned new investments included. It is important to note that this is an external assumption to the model, and the possibility of industrial activities shifting to regions with higher potential for renewables is not included. The planned new investments in the different industrial sectors were derived from bilateral conversations with the respective sector representatives. An exception is the production of refineries, which is assumed to decrease due to the decreasing international demand for fossil fuels.
- Population growth drives a slight increase in energy demand in the transport sector.
- Population growth also drives an increase in housing need, and renovation is modelled as an option in the model (residential and commercial sectors), which will cause a net decrease in heating demand in buildings.
- Under all scenarios, the lifetime of 2 GW of existing nuclear capacity (Doel 4 and Tihange 3) is extended by 10 years from 2025 until 2035¹¹⁻¹². It is assumed that the investments in nuclear lifetime extension are completed by 2025.
- Renewables take on an important role in the power sector, as demand for electrification is expected to increase. In this context, Belgium can invest in renewables up to its technical potential (see Table 18).
- Power interconnection capacity increases from 6.5 GW in 2020 to 13 GW by 2040, in line with TYNDP scenarios. The transmission capacity increase is included as an exogenous assumption for all scenarios without a cost allocation.
- International shipping and aviation are not included in the results. Also, non-CO₂ emissions – such as methane and N₂O in the agriculture sector – are not included.
- Electricity distribution grid upgrade costs are taken into account in a rudimentary way.
- The assumed hydrogen infrastructure costs are based on the definition of the Hydrogen Backbone for Belgium¹³ and a given investment cost, while for the distribution level, a tariff approach was defined. For CO₂ grid costs, these were taken into account by means of an estimation of shipping from the main ports (Antwerp and Ghent) and a transport tariff. In this way, the last mile delivery cost of CCS is taken into account for sites not in proximity to the backbone.

3.2 Central Scenario

Under the Central Scenario, it is assumed that Belgium's energy system will reach net zero emissions by 2050, driven by the cost of CO₂ emissions and climate targets, both at national and EU strategy level¹⁴. To reach carbon-neutrality, the sectors can invest in energy efficiency measures such as building renovation, more efficient vehicles, efficiency gains in space heating systems, and so on. Furthermore, new process technologies are modelled: fuel substitution, electrification, the use of synthetic molecules such as hydrogen or – for the industry and supply sector – Carbon Capture Utilisation or Storage (CCUS). When it comes to molecules, import of hydrogen or derivatives from outside of Belgium (EU and non-EU) is possible, with the import costs derived from international studies. The option of Carbon Capture and Storage (CCS) is not limited under the Central Scenario. Even though Belgium does not have its own storage locations for CO₂, it is assumed that Belgium will have unlimited access to the commercial phase of cross-border carbon storage in the North Sea and Norway.

11 <https://www.premier.be/fr/declaration-du-premier-ministre-et-de-la-ministre-de-l-energie>

12 https://www.belgium.be/sites/default/files/accord_de_gouvernement_2020.pdf

13 European Hydrogen Backbone, EHB, 2020. https://ehb.eu/files/downloads/2020_European-Hydrogen-Backbone_Report.pdf

14 https://climate.ec.europa.eu/eu-action/climate-strategies-targets/2050-long-term-strategy_en

Nonetheless, the results and insights generated by the three scenarios should be considered together as there is high uncertainty surrounding them, and the added value lies in exploring the differences between the scenarios.

3.3 Electrification Scenario

As an alternative to the Central Scenario, and in line with other long-term decarbonization studies (i.e., ELIA¹⁵, McKinsey¹⁶, ETIP¹⁷, Material Economics¹⁸), we explore the effect of having direct access to more offshore wind capacity and the option to invest in new nuclear technology under the Electrification Scenario.

Offshore wind

Under this scenario, investment in direct access with a 'High Voltage Direct Current' (HVDC) connection to 16 GW of the vast offshore wind potential in other parts of the North Sea is possible.

For the availability factor of offshore wind far from the North Sea (i.e., Doggerbank), we used a capacity factor of 60%. More important to estimate is the total capacity of additional offshore wind to which Belgium could have direct access. In the 'Esbjerg Offshore Wind Declaration' of 19 May 2022, Belgium, Germany, Denmark and the Netherlands signed an agreement to jointly build at least 150 GW of offshore wind capacity by 2050. We assumed that Belgium will have access to 16 GW of additional offshore potential outside of the Belgian territorial waters. To put this in perspective, the Netherlands recently increased their target to 70 GW by 2050, Germany to 50 GW and Denmark to 35 GW. For the investment cost assumption, we increased the cost of offshore wind with the cost of a 300 km HVDC cable connection and offshore converters, amounting to an additional 950 million €/GW.

Nuclear energy

Research into new nuclear technologies focused on 'Small Modular Reactors' is ongoing, which leads to the developing of different types of reactors – with an average size of 300 Mwe – that comply with the EU Taxonomy requirements of 'passive safety, minimization of long-lived waste and non-proliferation'. What if we allow investments in this new nuclear technology, assuming it could be operational from 2045 onwards?

Under the Electrification Scenario, we allow investments in SMR technology that complies with the most stringent EU Taxonomy guidelines: advanced technologies with closed fuel cycle ("Generation IV") to incentivise research and innovation into future technologies in terms of safety standards and minimising waste (with no sunset clause¹⁹). At this moment, different reactor concepts are under investigation. We did not differentiate between these different technologies, but we work with a synthesised plant being able to operate flexibly, with a high investment cost of 7500 €/kW, which is similar to current large Gen III design such as Hinkley Point in the UK. This number is assumed to include waste management steps and risk insurance.

Start year operation	Lead time [y]	Capex [€/kW]	Fixed OPEX [€/kW/yr]	Var OPEX [€/MWh]	Technical lifetime [y]	Efficiency [%]	Annual availability [%]
2045	9	7500	83.3	7.52	60	33	80

Table 1. Main parameters related to new nuclear power plants.

3.4 Clean Molecules Scenario

Under the Clean Molecules Scenario, we examine the impact of having synthetic molecules imports at lower costs and limited access to cross-border CO₂ storage.

Green hydrogen import

The production cost of synthetic molecules such as green hydrogen and derivatives is highly dependent on the electricity cost. Plans are being made to build up large electrolyser capacities at locations outside the EU, where abundant renewable capacity is available to produce electricity and green molecules at low cost. In its federal hydrogen strategy, Belgium expressed the ambition to become a large import hub for hydrogen.

15 Roadmap to net zero, ELIA group, 2021.

https://www.elia.be/-/media/project/elia/shared/documents/elia-group/publications/studies-and-reports/20211203_roadmap-to-net-zero_en.pdf

16 How the European Union could achieve net-zero emissions at net-zero cost, McKinsey, 2020.

<https://www.mckinsey.com/capabilities/sustainability/our-insights/how-the-european-union-could-achieve-net-zero-emissions-at-net-zero-cost>

17 Getting fit for 55 and set for 2050, ETIP and Wind Europe, 2021. <https://etipwind.eu/publications/getting-fit-for-55/>

18 Industrial Transformation 2050 (Exhibit 1.11), Material economics, 2019.

<https://www.climate-kic.org/wp-content/uploads/2019/04/Material-Economics-Industrial-Transformation-2050.pdf>

19 Source Q&A: EU Taxonomy Complementary Climate Delegated Act (Europa.eu)

Today, there are more locations worldwide to produce green hydrogen than there are countries with oil or natural gas resources. What if Belgium could have access to these synthetic molecules at a hydrogen price that is almost 30% lower by 2050 (H₂ at 1.7 €/kg) compared to the Central Scenario?

While import of ammonia is also possible in the model, it is the explicit assumption in this model that current ammonia production is not displaced and remains in Belgium.

Limit on Carbon Capture and Storage

Belgium has no natural locations to store future captured CO₂ emissions from industry or the power sector. To ship and store Belgian CO₂ emissions, we will have to rely on contracts with neighbouring countries such as the Netherlands and Norway, which are developing storage sites by reconverting old natural gas fields. These storage locations are expected to enter their commercial phase within the next following years. What if Belgium has limited access of 5 Mton/y to these cross-border storage locations?

LCOH [€/kg]	2020	2030	2050
Central and Electrification Scenarios	4.50	2.91	2.37
Clean Molecules Scenario	4.50	2.16	1.71

Table 2. Levelized cost of hydrogen import in Belgium under the three main scenarios. The last mile delivery cost within Belgium is distance-dependent and not included in this number.

3.5 Scenarios overview

What will be the impact on the CO₂ reduction path towards 2050 and how will the costs be impacted in comparison with the Central Scenario?

Parameter	Central Scenario	Electrification Scenario	Clean Molecules Scenario
New nuclear (SMR)	No investments in new nuclear possible.	Investment in new SMR possible, in operation >2045; SMR in line with EU taxonomy.	Same as Central Scenario.
Offshore	The offshore potential is limited to the Belgian North Sea.	Investment in direct access to 16 GW far offshore projects possible, capacity factor 60%.	Same as Central Scenario.
Carbon capture & storage (CCS)	No limitation to carbon capture & storage.	Same as Central Scenario.	The carbon capture process is not limited, but limited access to storage potential to 5 Mton/y.
Molecule import	Molecule import at H ₂ cost (LCOH) of <ul style="list-style-type: none"> 2020: 5.0 €/kg_{LHV} (150 €/MWh) 2030: 3.2 €/kg_{LHV} (97 €/MWh) 2050: 2.6 €/kg_{LHV} (79 €/MWh) 	Same as Central Scenario.	Molecule import at lower H ₂ cost (LCOH) of <ul style="list-style-type: none"> 2020: 5.0 €/kg_{LHV} (150 €/MWh) 2030: 2.4 €/kg_{LHV} (72 €/MWh) 2050: 1.9 €/kg_{LHV} (57 €/MWh)

Table 3. Parameters which vary under the three main scenarios.

In addition to the three main scenarios already described, sensitivity cases are also part of the study to deeply analyse the impact of important assumptions or parameters with a high level of uncertainty, such as nuclear SMR investment cost, PV efficiency improvements and access to carbon storage facilities (CCS). Thus, six sensitivity cases leading to ten sensitivity model runs were defined, which are described in Table 4, and their results are explained in more detail in Section 7.

Sensitivity case	Reference scenario	Definition	Different model runs
Offshore wind	Central Scenario	Additional access to large offshore wind zones in the North Sea from 2030 and to a maximum of 16GW or 32GW by 2050, on top of the 8 GW in the Belgian territorial zone.	Direct connection to 16 GW additional offshore capacity. Unlimited access to additional offshore capacity.
PV efficiency and cost	Electrification Scenario	This case is made up of two sensitivities. In the first, PV efficiency increases from 23% to 35% (e.g.: tandem cells). In the second sensitivity, PV is forced to go to 75% of its technical potential by 2040.	PV efficiency from 23% to 35%. Forced quicker deployment of PV.
Small Modular Reactor (SMR)	Central Scenario	Without access to additional offshore wind, SMR might play a more relevant role. However, to account for uncertainty, the impact of lower and higher investment costs is considered.	SMR at 4,500 €/kW SMR at 7,500 €/kW as in the Central Scenario SMR at 10,800 €/kW
Industry flexibility	Electrification Scenario	Possible investment in flexibility for some key industrial demands, where the annual production of intermediate and final products remains stable. Additional capacity comes at a cost but allows to produce more during periods of low energy prices (or costs) and less during periods of higher energy prices. The following industrial sectors/processes, which can technically provide flexibility, are included: chlorine, steel (EAF, MOE), copper, zinc and chemical sector (electrical cracking furnaces).	Selected processes can invest in additional capacity and operate at different levels each period (2 hours).
Carbon storage limitation	Electrification Scenario	There is limited access to cross-border CO ₂ storage: Belgium's access to cross-border CO ₂ storage is limited to 5 million tons per year.	Maximum CCS use of 5 MtCO ₂ .
Near-zero emissions (85% reduction)	Central Scenario	In contrast to the other cases, this sensitivity does not reach net zero carbon emissions. Here, a carbon price, reaching €350/tCO ₂ in 2050, is the sole decarbonization driver. There is no net zero constraint by 2050.	No net zero constraint by 2050.

Table 4. Description of sensitivity cases.

4. Demand sectors

4.1 Macroeconomic assumptions

The future energy landscape will be driven by changes in final energy demand and consumption patterns across all sectors (industry, residential & commercial, transport, agriculture). Therefore, demand projections are a crucial input for any energy system model. TIMES-BE differentiates between service demands (i.e., space heating, passenger transportation), product output (i.e., steel, ammonia, bricks) and energy demands (i.e., annual energy consumption in PJ or TWh).

Main assumptions used for future sector demands:

- **Industry:** In 2050, the throughput of products will have the same level as in 2020. Already planned new investments, such as the investments in the blast furnaces in Arcelor Mittal, are taken into account.
- **Transport:** Annual demand of passenger-km, tonne-km and energy demand are taken from the results of the TREMOVE model developed by Transport and Mobility Leuven (TML)²⁰.
- **Residential:** Final energy services demand is driven by population growth according to the Federal Planning Bureau. The population is assumed to increase from 11.5 million in 2020 to 12.4 million by 2050²¹.
- **Commercial:** Final energy services demand is driven by economic growth projections according to the Federal Planning Bureau²².
- **Agriculture:** Energy demand will remain at the same level as it is today. Agriculture energy consumption, although with yearly variations, has been rather stable in the course of the last 20 years. Greenhouse gas emissions from non-CO₂ sources (methane, N₂O) are not taken into account.
- **Transformation:** The transformation sector, which includes refineries and the power sector, reflects the changes in demand sectors. Nonetheless, as Belgium exports a large volume of petroleum products, refineries are set to follow the downward trend in crude intake expected by CONCAWE as a low boundary of their activity²³.

TIMES discounts all costs of the energy system to a user-selected year. Additionally, the model uses the discount rate to calculate the annualized payment of the investment cost of each process. TIMES offers the possibility to define different discount rates for each process or sector (e.g., industry, residential). TIMES-BE works with a discount rate of 3%. Additionally, there is the alternative to use sector-specific rates. Nonetheless, in this exercise, and aligned with analysis on discount rates in energy system studies²⁴, a discount rate of 3% over all sectors is chosen for consistency reasons, avoiding the individual investor perspective and opting for a more social or macroeconomic one.

TIMES-BE considers only the underlying techno-economic costs of the system and does not take into account taxes, subsidies, etc. For instance, the costs of electricity and distribution grids are taken into account, but non-technical costs such as green certificates and social tariffs are not. This is an explicit choice made in the model, as this allows a view of the energy system which is unbiased by politically inspired taxes and subsidies.

4.2 Industry

As mentioned before, we assume that industrial activity in Belgium will stay mostly constant in the coming decades, with only some changes due to planned investments. This, in other words, means that the current production of goods such as steel, ethylene, ammonia or cement is considered to have similar levels by 2050. As such, this study explores the changes that the industry will undergo to reduce its carbon footprint and comply with national and European targets. In TIMES-BE, each industry has a set of decarbonization alternatives available, grouped by decarbonization strategy as it is explained in this chapter in the section for each industrial sub-sector. The current activity levels and energy demand of the industry used in TIMES-BE are presented in Table 5. According to the Belgian energy balance, the final energy consumption of the industry prior to the COVID-19 pandemic was 148.3 TWh²⁵, while the final non-energy consumption was 81.1 TWh²⁶. During the same period, the industry was responsible for 23.1% (34.18 MtCO₂) of the total Belgian GHG emissions²⁷. Compared with 1990 values, the sector has reached a reduction of 31.1%, which reflects the effort of several sectors to reduce their carbon intensity.

20 Projections done within the Energy Transition Found project EPOC. <https://www.tmlleuven.be/en/navigation/TREMOVE>
21 Demografische vooruitzichten 2020-2070, Federal Planning Bureau, 2021. (pg.3)

https://www.plan.be/uploaded/documents/202103310840330.FOR_POP2070_12389_N.pdf
22 Economische vooruitzichten 2021-2026 (Table 7), Federal Planning Bureau, 2021.

https://www.plan.be/uploaded/documents/202102260904210.Rapport_feb2021_12364_N.pdf

23 A demand reduction of all refinery products of 43% compared with 2014 levels from Refinery 2050: Conceptual Assessment (Table3.3-2), CONCAWE, 2019.
https://www.concawe.eu/wp-content/uploads/Rpt_19-9-1.pdf

24 Steinbach J, Staniaszek D. Discount rates in energy system analysis Discussion Paper.

https://www.bpie.eu/wp-content/uploads/2015/10/Discount_rates_in_energy_system-discussion_paper_2015_ISI_BPIE.pdf

25 Industrial final energy consumption plus coal and coke input in coke oven and blast furnace.

26 Eurostat Energy balance 2019.

27 Sectoral shares in Belgium in 2019. <https://www.eea.europa.eu/data-and-maps/data/data-viewers/greenhouse-gases-viewer>

Sector	Sub-sector	Product	Unit	Demand/production	Sources
Iron and Steel	Virgin steel	High-quality steel	Mt	5.14	Worldsteel ²⁸
	Scrap based steel	Low quality steel	Mt	2.46	
Chemical & petrochemical	Fertilizers	Ammonia	Mt	0.98	BE GHG inventory ²⁹
	Based chemicals	Chlorine	Mt	0.91	Euro Chlor ³⁰ , Ineos ³¹
		Ethylene Oxide	Mt	0.83	Ineos ³² , O.Tech ³³
	High-Value-Chemicals	Ethylene	Mt	1.35	Petrochemicals Europe ³⁴ , JRC ³⁵
		Propylene	Mt	1.52	
		BTX	Mt	0.70	
		C4	Mt	0.66	
	Other industries	Energy demand	TWh	25.5	Eurostat ³⁶
Non-ferrous metals	Detail production	Copper	Mt	0.39	BGS ³⁷
		Zinc	Mt	0.25	USGS ³⁸
	Other NFM	Energy demand	TWh	1.16	Eurostat ³⁵
Non-metallic minerals	Cement	Cement	Mt	6.64	FEBELCEM ³⁹
	Lime	Lime	Mt	1.90	CLIMAT ⁴⁰
	Glass	Container glass	Mt	0.26	CLIMAT ⁴¹
		Flat glass	Mt	0.97	
		Fibreglass	Mt	0.32	
	Bricks	Façade	Mt	1.59	BRIQUE ⁴²
		Regular	Mt	0.94	BRIQUE ⁴³
	Other NMM	Energy demand	TWh	3.54	Eurostat ³⁵
Food, beverages & tobacco	Flanders	Energy demand	TWh	10.08	Flemish energy balance
	Brussels & Wallonia	Energy demand	TWh	3.08	Walloon energy balance
Paper, pulp & printing	Pulp and paper production	Non-wood containing	Mt	0.52	CEPI ⁴⁴
		Wood containing paper	Mt	0.16	
		Recycled paper	Mt	1.37	

28 https://www.worldsteel.org/en/dam/jcr:7f5a36e2-e71e-4c58-b93f-f78d0c5933e4/WSIF_2015_vfinal.pdf

29 https://cdr.eionet.europa.eu/be/eu/mmr/art07_inventory/ghg_inventory/envxm3wfw/BEL_2020_2018_13032020_080456_started.xlsx/manage_document

30 https://www.eurochlor.org/wp-content/uploads/2019/05/euro_chlor_industry_review_FINAL.pdf

31 <https://www.ineos.com/businesses/ineos-oxide/news/ineos-oxide-eo-and-derivatives-expansion-at-antwerp/>

32 <https://www.ineos.com/businesses/ineos-oxide/news/ineos-oxide-eo-and-derivatives-expansion-at-antwerp/>

33 <https://www.offshore-technology.com/marketdata/basf-antwerp-complex-belgium/>

34 <https://www.petrochemistry.eu/about-petrochemistry/petrochemicals-facts-and-figures/cracker-capacity/>

35 <https://ec.europa.eu/jrc/en/publication/eur-scientific-and-technical-research-reports/energy-efficiency-and-ghg-emissions-prospective-scenarios-chemical-and-petrochemical>

36 Eurostat remaining energy and non-energy demand after discounting the detailed model process within the sector.

37 British Geological Survey (pg.21), 2020. https://www2.bgs.ac.uk/mineralsuk/download/world_statistics/2010s/WMP_2014_2018.pdf

38 Minerals Yearbook (Table 10), U.S. Geological Survey, 2016.

<https://d9-wret.s3.us-west-2.amazonaws.com/assets/palladium/production/mineral-pubs/zinc/myb1-2014-zinc.pdf>

39 https://www.febelcem.be/fileadmin/user_upload/rapports_annuels/nl/RA_Febelcem_NL_2019.pdf

40 <https://climat.be/doc/nir-15-april-2020-final.pdf>

41 <https://climat.be/doc/nir-2021-150421.pdf> (Tables 4.3 and 4.4)

42 <https://www.brique.be/secteur-briquetier/le-secteur-en-quelques-chiffres/>

43 <https://www.brique.be/media/2348/2021-rapport-annuel-fbb-version-publique.pdf>

44 <https://www.cepi.org/wp-content/uploads/2021/01/Key-Statistics-2014-FINAL.pdf>

Other industries	Transport equipment	Energy demand	TWh	1.39	Eurostat
	Machinery	Energy demand	TWh	3.33	Eurostat
	Mining & quarrying	Energy demand	TWh	0.60	Eurostat
	Wood & wood products	Energy demand	TWh	1.09	Eurostat
	Construction	Energy demand	TWh	2.35	Eurostat
	Textile & leather	Energy demand	TWh	2.15	Eurostat
	Not-elsewhere-specified	Energy demand	TWh	3.74	Eurostat
Non-energy demand	Non-energy demand	Feedstock	TWh	18.98	Eurostat ³⁵

Table 5. Industrial production levels in the TIMES-BE model.

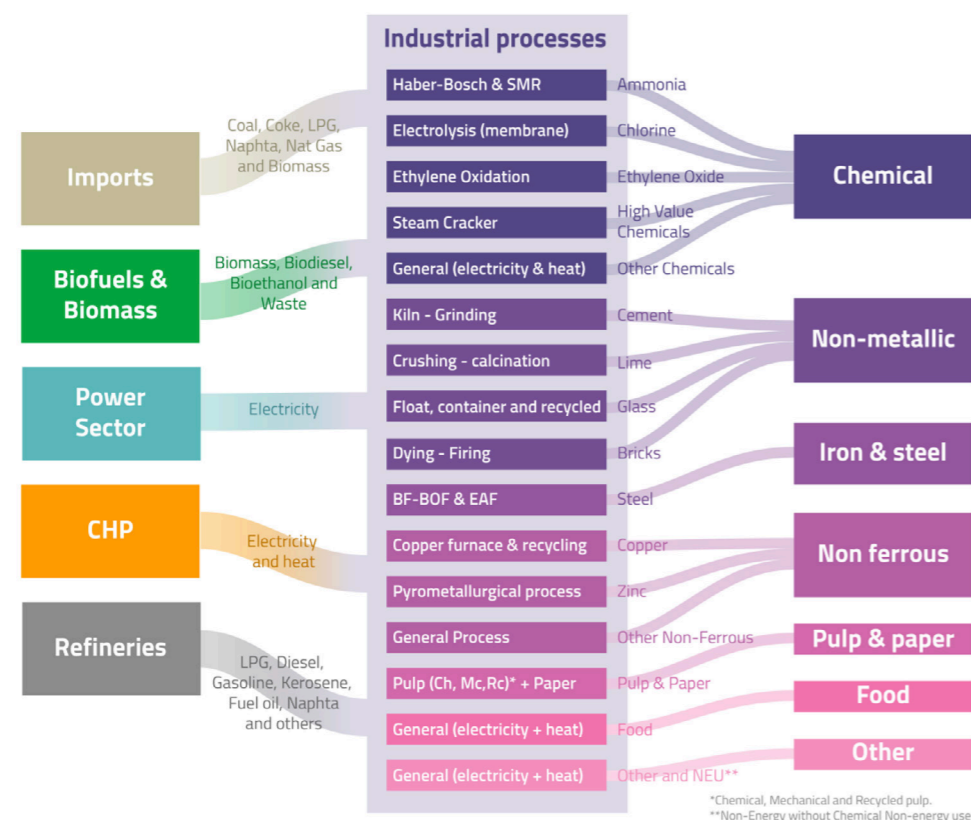

Figure 2. Industrial sub-sectors covered in detail in TIMES-BE and their main products.

4.2.1 Steel sector

The existing steel production technologies in Belgium are the Blast Furnace – Basic Oxygen Furnace (BF-BOF), which is assumed to be used for high-quality steel, and the electric arc furnace (EAF), used mostly for low-quality steel. The steel sector is generally divided into iron ore pre-treatment, iron reduction, steel production, rolling and casting, auxiliary processes and finishing and forming (the latter process represents small and distributed companies at the end of the supply chain). The energy and mass balance for each process was defined on the basis of literature reviews, sector reports and the Belgian energy balance available in Eurostat. The age of the assets is another important parameter to consider; thus, the technical lifespan of the steel assets is constantly extended by annual investments. On the other hand, after a couple of decades, furnaces could undergo an overhaul process, as happened at the ArcelorMittal plant in Ghent⁴⁵. In the steel sector, it is important to differentiate between process and combustion emissions. Process emissions are estimated at about 80% of the total emissions. Moreover, the use of blast furnace gas for the production of electricity is accounted for in the power sector, which reduces the emissions allocated to the steel sector. There are two main strategies for the steel sector: hydrogen for the direct reduction of iron (DRI) and CCUS. These strategies are in line with sector associations' roadmaps. For instance, EUROFER estimates that by 2050 the steel sector will consume 400 TWh (seven times the current EU steel industry current demand) for electric processes and hydrogen production⁴⁶. Additionally, steelmaking in Europe will need to reduce around 21 MtCO₂/yr. through CCUS, this value could be higher depending on the availability of electricity and hydrogen⁴⁵.

⁴⁵ <https://www.spglobal.com/commodityinsights/en/market-insights/latest-news/metals/020121-arcelormittal-confirms-ghent-blast-furnace-to-restart-production-by-mid-feb>

⁴⁶ LOW CARBON ROADMAP (pg. 13), EUROFER, 2019. <https://www.eurofer.eu/assets/Uploads/EUROFER-Low-Carbon-Roadmap-Pathways-to-a-CO2-neutral-European-Steel-Industry.pdf>

Demand/Product	Current process	Fuel replacement	Hydrogen/ Molecules	Electrification	Carbon Capture & Storage/ Reuse CCUS
High-quality steel	Blast Furnace-Blast Oxygen Furnace (BF-BOF)	Blast Furnace-H ₂ injections Blast Furnace-Plastic use	Hydrogen -Direct Reduction (DRI) H ₂ -based heat (finishing)	Molten Oxide Electrolysis Electrowinning	BF-BOF/ with carbon capture & storage Natural Gas -DRI/CCUS
Low-quality steel	Electric Arc Furnace (EAF)	Electric Arc Furnace (Electricity + Biomass)		Electric Arc Furnace (100% Electricity)	CCUS

Table 6. Emission reduction options for the steel sector in the TIMES model, grouped by strategy.

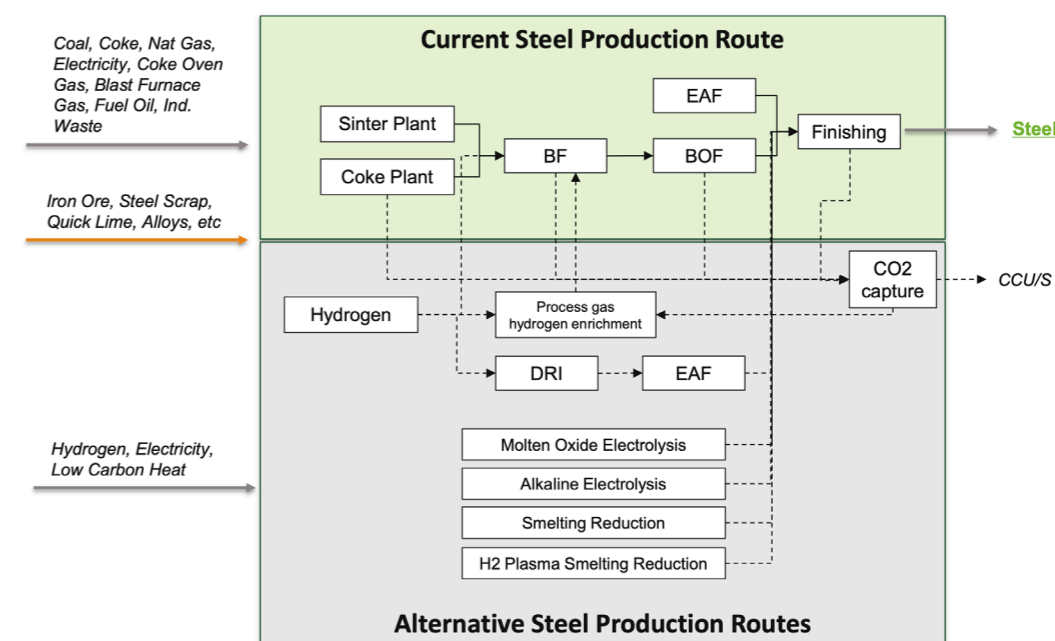

Figure 3. Steel current and alternative production routes in TIMES-BE (simplified).

4.2.2 Chemical sector

The chemical sector is responsible for 39% of the industrial final energy demand and a large part of the non-energy demand (feedstock). In TIMES-BE, the production of seven final products is modelled in detail: ammonia, chlorine, ethylene oxide, ethylene, propylene, C4s and BTX. Together, these products account for 64% of the energy and non-energy demand of the chemical sector. The remaining 36% is modelled as energy consumption.

The model takes into account carbon reduction commitments and the increase in the cost of energy-intensive products, which are two main factors that determine the risk of carbon leakage, i.e., industries moving away to other parts of the world with more abundant access to renewables⁴⁷. However, carbon leakage is not part of this study as we explicitly assume industrial production to be present in Belgium by 2050.

⁴⁷ <https://climatepolicyinfohub.eu/carbon-leakage-and-industrial-innovation.html>

Demand/Product	Base Technologies	Hydrogen/Molecules	Electrification	Carbon Capture and Storage/Utilization (CCU/S)
Ammonia	Haber-Bosch (SMR)	- Haber-Bosch (H ₂)	n.a.	<ul style="list-style-type: none"> Pyrolysis SMR+CCUS
Chlorine	Membrane cell electrolysis	n.a.	n.a.	n.a.
Ethylene Oxide	Catalyst synthesis	n.a.	n.a.	n.a.
High-Value Chemicals	Naphtha cracker PDH	<ul style="list-style-type: none"> Methanol to Olefins (MTO) Methanol to Aromatics (MTA) Methanol to Propylene (MTP) 	<ul style="list-style-type: none"> Electric furnace 	<ul style="list-style-type: none"> Crackers & CCS
Other chemicals	Energy demand process (machine drive and heat)	<ul style="list-style-type: none"> Hydrogen boiler Hydrogen burner 	<ul style="list-style-type: none"> Heat pumps Electric boiler Electric heaters 	

Table 7. Emission reduction options for the chemical sector grouped by strategy.

Ammonia

Ammonia production in Belgium is done at two plants: one in Antwerp, owned by BASF and one in Tertre, owned by Yara. Both plants are represented in TIMES-BE as one unique Haber-Bosch process coupled with a Steam Methane Reformer (NG/SMR). The options to decarbonize the production of ammonia include the integration of CCUS into the existing processes - which already includes a CC unit to capture process related emissions to prevent damaging the catalyst for the ammonia synthesis. This highly pure CO₂ stream is already captured and used in downstream utilizations such as urea production or the food industry. The remaining combustion emissions, which represent 1/3 of the total emissions, can be captured by installing an additional CC unit. This configuration (Natural Gas/Steam Methane Reforming + carbon capture) produces the so-called blue hydrogen needed in the Haber-Bosch. A different alternative to grey hydrogen or blue hydrogen is the production of yellow hydrogen - hydrogen produced with grid electricity - both onsite or centralized, or the use of imported green hydrogen. In such cases, there is a need to provide nitrogen for ammonia synthesis using an Air Separation Unit (ASU). Nitrogen is currently obtained from steam methane reforming.

The chemical sector has been working towards making the low-carbon European economy a reality. In 2013, CEFIC already identified the fundamental role that energy efficiency, decarbonizing heat production and CCS will play by 2050, as well as the need to further explore and develop CCU cases⁴⁸. DECHEMA identified the potential of so-called blue hydrogen in the effort to reach the 2030 targets, however, they also highlighted the limited availability of CO₂ storage sites by 2030⁴⁹.

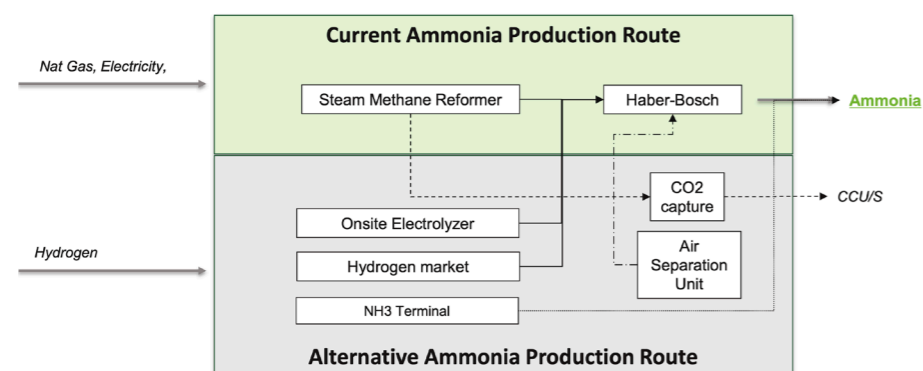

Figure 4. Ammonia current and alternative production routes in TIMES-BE (simplified).

Chlorine

Chlorine production in Belgium is done by INOVYN and Vynova at three different sites. The production is mostly done through membrane cell electrolysis (93%), while the rest is done with mercury cell electrolysis. Being the former is the most recent and commonly used route worldwide. This process has already been fully electrified and produces hydrogen as a by-product. Consequently, chlorine production has no direct CO₂ emissions. For this reason, in TIMES-BE, chlorine is always produced through the membrane cell electrolysis and refurbishment of existing assets is considered.

48 https://cefic.org/app/uploads/2019/01/Energy-Roadmap-The-Report-European-chemistry-for-growth_BROCHURE-Energy.pdf

49 https://dechema.de/dechema_media/Downloads/Positionspapiere/Studie+Ammoniak.pdf

The hydrogen that is obtained as a by-product (0.03Mth₂) is assumed to currently be consumed within the industry and thus is not available for new processes such as DRI steelmaking.

High-Value Chemicals

High-Value Chemicals (HVC) cover the production of ethylene, propylene, BTX and C4s. The production of HVC is concentrated in a few production sites (Naphtha crackers and propane dehydrogenation) in the port of Antwerp. Each of these plants has a different design and then, different yields and energy intensities. In TIMES-BE, the three Naphtha crackers are included as a single process with the weighted average yield and energy intensity of the existing crackers. The combined production capacity of the Naphtha crackers is 2.24Mta (this number is referring to the yearly ethylene production capacity)⁵⁰, while the propane dehydrogenation (PDH) has a capacity of 0.55Mta (referring to the yearly propylene production capacity). The cracker was split into the furnace and the cracking part, which allows the model to consider alternatives such as the electrification of the furnace without affecting the cracking step. This has an impact on investments, as it is assumed that the cracking step will be operational beyond 2050. Additionally, TIMES-BE considers the export of HVC, similarly to oil products from refineries, since the boundaries of the model do not reach detailed downstream processes and Belgium is part of a complex trading network within Europe. The main emission reduction options for the Naphtha crackers are the electrification of the furnace or the installation of carbon capture units. More disruptive options include the use of methanol as a base molecule for the production of olefins (MTO) and aromatics (MTA), or a two-step production from natural gas (currently in the lab stage and not included in TIMES-BE)⁵¹. The production of propylene is partially covered by the steam cracker routes, nonetheless there are other production routes such as the methanol-to-propylene⁵² (MTP) or the installation of a carbon capture unit.

The future envisioned by HVC producers involves changes to the Naphtha crackers instead of exploring disruptive, but not yet ready, technologies. For example, Project ONE by INEOS includes the use of hydrogen, partial electrification of the furnace, energy efficiency and CCUS to reach an initial reduction of 67% in CO₂ emissions compared to the average Naphtha cracker⁵³. Other important companies in the sector such as BASF, SABIC and Linde announced the construction of a fully electrified Naphtha cracker⁵⁴. Therefore, in TIMES-BE, the need for fossil-based feedstock (i.e.: Naphtha, LPG, natural gas) is considered whether furnaces are electrified or CCUS is deployed; this amounts to 80 TWh. A fossil-based feedstock does not necessarily lead to increased emissions, as long as the carbon in the feedstock is contained within the final product and not released as CO₂ into the atmosphere. Nonetheless, the fossil-based feedstock can be replaced by clean molecules routes such as MTO and MTA, or synthetic production of Naphtha through Fischer-Tropsch.

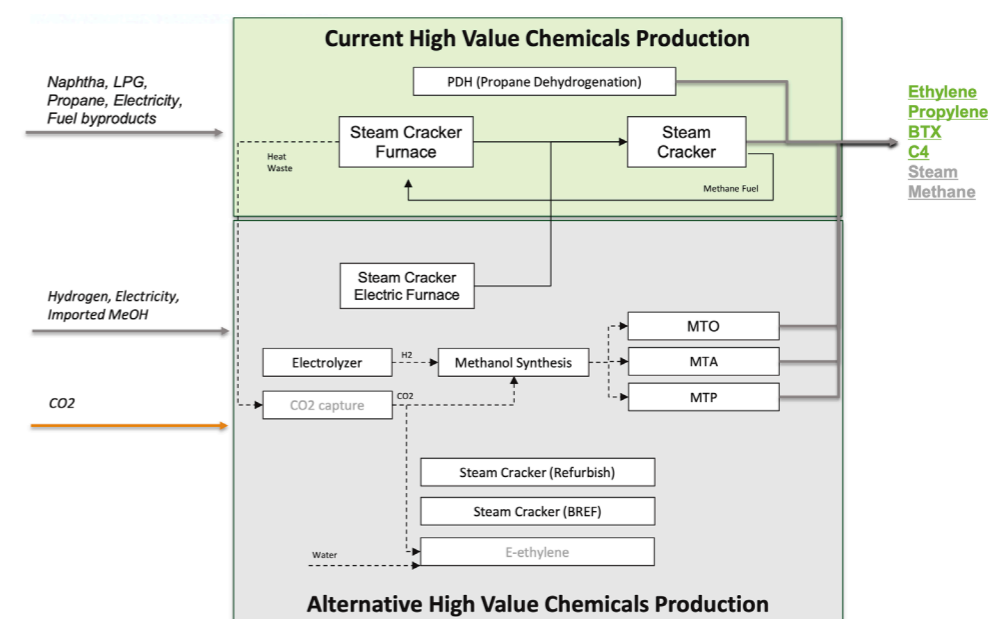

Figure 5. High-Value Chemicals current and alternative production routes in TIMES-BE (simplified).

50 <https://www.petrochemistry.eu/about-petrochemistry/chemicals-facts-and-figures/cracker-capacity/>

51 https://sc.edu/study/colleges_schools/engineering_and_computing/news_events/news/2021/producing_ethylene_environmentally_safe_process.php#:~:text=The%20principal%20method%20of%20producing,degrees%20Celsius%2C%E2%80%9D%20Chen%20says.

52 [https://www.engineering-airliquide.com/lurgi-mtp-methanol-propylene#:~:text=Lurgi%20MTP%E2%84%A2%20%2D%20Methanol%2Dto%2DPropylene%20\(MTP\),a%20variety%20of%20petrochemical%20processes.](https://www.engineering-airliquide.com/lurgi-mtp-methanol-propylene#:~:text=Lurgi%20MTP%E2%84%A2%20%2D%20Methanol%2Dto%2DPropylene%20(MTP),a%20variety%20of%20petrochemical%20processes.)

53 A bridge to a more sustainable future for Antwerp chemicals (Table 1), INEOS, 2021. https://project-one.ineos.com/wp-content/uploads/2021/06/NEO21-033-Position_WP_Project_ONE_21_06_EN_V18.pdf

54 <https://www.basf.com/global/en/who-we-are/sustainability/whats-new/sustainability-news/2022/basf-sabic-and-linde-start-construction-of-the-worlds-first-demonstration-plant-for-large-scale-electrically-heated-steam-cracker-furnaces.html>

Ethylene oxide

Ethylene oxide is produced from ethylene. Thus, there is a strong link between its production and the Naphtha crackers. In fact, in TIMES-BE, part of the ethylene produced in the Naphtha cracker, or any other alternative, goes to the ethylene oxide plant. This process was selected to be modelled in detail due to the high CO₂ concentration in the flue gases, which makes it an attractive case for carbon capture. Additionally, BASF announced to increase the ethylene oxide production capacity in Belgium with a new plant of 0.4 Mta⁵⁵. To reduce the emissions of this process, not taking into account upstream emissions, carbon capture technologies are the main alternative. Another way to reduce CO₂ emissions is the use of a supersonic separator that increases the plant's yield by recovering feedstock from the waste and by-products within the same production process.

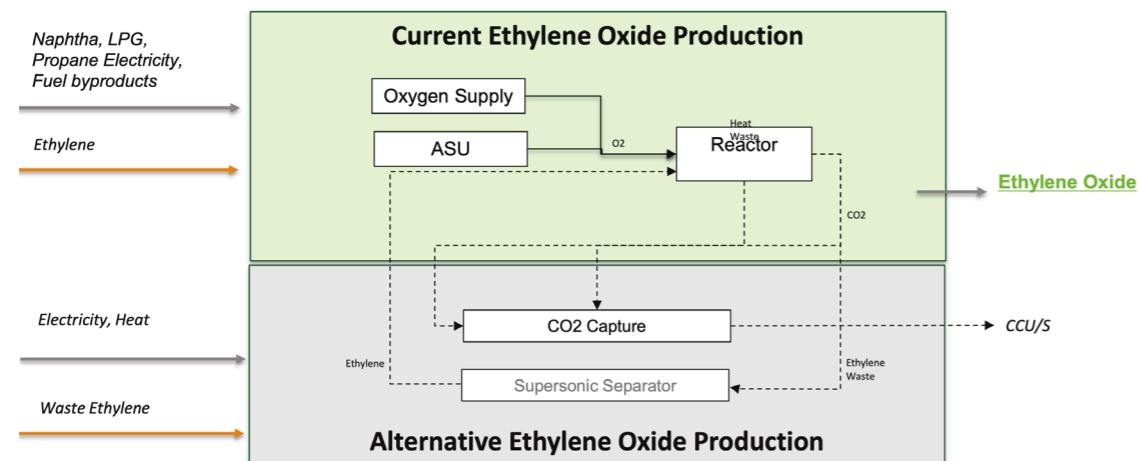

Figure 6. Ethylene oxide current and alternative production routes in TIMES-BE (simplified).

Other Chemical Industries

Finally, the remaining energy consumption of the chemical sector is allocated to Other Chemical Industries. For these chemical processes, there are no detailed data, therefore it is modelled following a top-down approach. In other words, there is a fixed energy demand which is met by providing high-temperature heat, low-temperature heat, electricity and machine drive. Most of the energy used in Other Chemical Industries is for heating purposes. It is assumed that the heat demand above 400°C in the chemical sector is mostly attributed to the sectors which are explicitly modelled in TIMES-BE (i.e., ammonia, HVC and ethylene oxide). Nearly 20% of heat demand in the chemical sector is below 100°C and 30% between 100°C and 400°C. To decarbonize the heat demand of Other Chemical Industries, there are several alternatives for low- and mid-temperature heat. These alternatives include heat pumps, which for low-temperature are already available⁵⁶ and for mid-temperature are expected to be mature enough in the mid-term by developing hybrid or multistage heat pumps⁵⁷⁻⁵⁸. On the other hand, heat demand can also be supplied by hydrogen-based solutions.

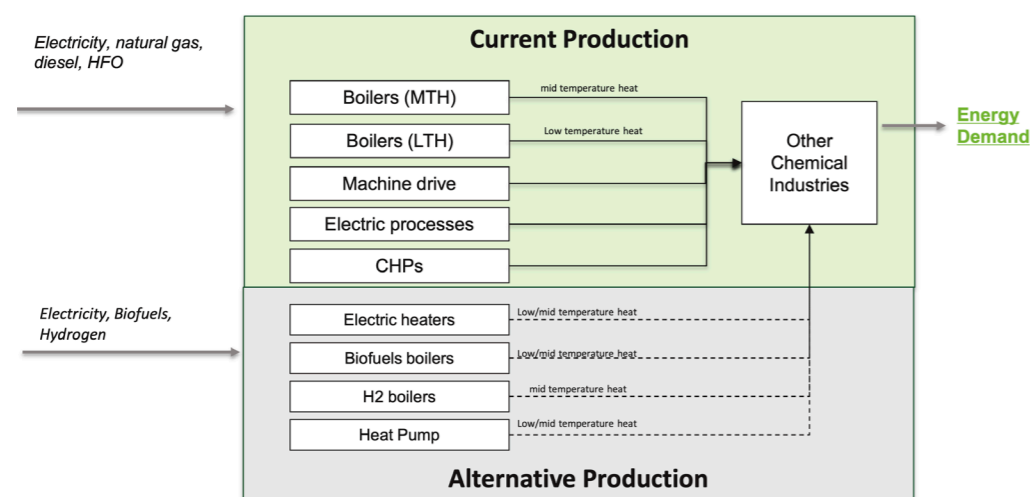

Figure 7. Other Chemical Industries' current and alternative production routes in TIMES-BE (simplified).

55 <https://www.basf.com/global/en/media/news-releases/2019/09/p-19-336.html>
 56 https://www.ehpa.org/fileadmin/red/03_Media/03_02_Studies_and_reports/Large_heat_pumps_in_Europe_MDN_II_final4_small.pdf
 57 <https://www.enertime.com/en/solutions/heat-pumps>
 58 <https://www.sciencedirect-com.proxy.library.uu.nl/science/article/pii/S1364032122000351>

4.2.3 Non-metallic minerals

Non-metallic minerals include cement, lime, glass, bricks and other non-metallic mineral industries (NMM). The NMM industry accounts today for 13% (15.5 TWh) of the industrial final energy demand and 9.5% (7.9 MtCO₂) of total CO₂ emissions in Belgium. Nearly half of the emissions in the sector are non-energy related process emissions (4.4 MtCO₂). In TIMES-BE, the production of four final products is modelled in detail: cement, lime, glass and bricks. The final energy demand that is not included in the production of these products (around 22% or 3.5 TWh) is allocated to other non-metallic mineral industries and modelled as energy consumption.

In TIMES-BE, the production route for these products for the base year and future alternatives are modelled separately. In the case of glass and bricks, there is a further differentiation of final products, namely fibreglass, flat and hollow glass, or façade and regular bricks. The technologies considered for reducing emissions in this sector are shown in Table 8. In this section, we further describe the characteristics of the sub-sector and the emission reduction options.

	Current Technologies	Fuel replacement	Hydrogen/ Molecules	Electrification	CCU/S
Cement	Kiln, milling, grinding	Waste and biomass	H ₂ Kiln	Partial electrification (plasma)	Calcium looping Oxy combustion
Bricks	Drying and furnace	Synthetic CH ₄	H ₂ heaters	Microwave heaters	Amine absorption
Glass	Container, Flat, Fiberglass	Synthetic CH ₄	H ₂ -based heat	100% electric (flat, hollow) Electric boosting (Fiberglass)	Amine absorption
Lime	Calcination and milling	Waste and biomass	H ₂ substitution of fuel in Kiln	Partial electrification (plasma)	Amine absorption
Other Non-metallics	Machine drive Low-temperature heat (LTH) High-temperature heat (HTH)		H ₂ -based high-temperature heat	Electric tunnel kiln for high-temperature heat Heat pumps (LTH)	

Table 8. Emission reduction options for the non-metallic minerals sector.

Cement

The cement sector in Belgium is spread across different regions, while clinker production is concentrated in Wallonia⁵⁹. There are several types of cement based on their production characteristics as well as on their final use. CEMBUREAU defines five types of cement based on the clinker-to-cement ratio⁶⁰. To simplify the cement production, TIMES-BE considers only one type of cement demand, which is produced using blast furnace slag and clinker, with a clinker-to-cement ratio of 0.7, in line with European values⁶¹. The production of cement in TIMES-BE is modelled in such a way as to represent the main steps, namely raw mill, kiln and precalciner, and cement mill. Today, 70% (3.38 TWh) of the thermal consumption in the sector - almost entirely dedicated to the kiln and precalciner - is provided by fossil fuels, while the remaining part comes from biofuels and waste. These values are aligned with the European estimated average consumption⁶². However, the increasing share of biomass and waste in the kiln has a limitation for reducing the emission of the cement sector, as roughly 2/3 of the emissions are attributed to the calcination of limestone, which are the so-called process emissions. TIMES-BE was designed to model process and combustion emissions separately, which allows the model to find alternatives to produce the heat needed in the kiln, while for the process emission, CCUS options are explored.

For instance, hydrogen has the capacity to reach the high temperature required in the kiln (1400°C), however the quality and type of flame are not ideal to dissipate the heat uniformly across the kiln on top of additional technical challenges that might require further research and development⁶³. This is considered as an alternative in the model to partially replace other fuels in the kiln. The same situation is seen for the use of a plasma torch⁶⁴. In Europe, the cement sector explores several alternatives. For 2030, the CEMBUREAU roadmap considers seeking further energy efficiency gains, increased fuel replacement and clinker substitution. In the same roadmap, by 2050, the cement sector expects to reduce CO₂ emissions by using decarbonated raw materials, increasing the use of biofuels and using H₂ and electricity in the kiln⁶⁵.

59 <https://www.cemnet.com/global-cement-report/country/belgium>

60 <https://cembureau.eu/about-our-industry/cement/>

61 <https://lowcarboneconomy.cembureau.eu/5-parallel-routes/resource-efficiency/clinker-substitution/>

62 Deep decarbonization of industry: The cement sector (Figure 1, 54% fossil fuels, 30% waste and 16% biomass), European Commission JRC, 2020. https://ee-ip.org/fileadmin/user_upload/IMAGES/Articles/JRC120570_decarbonisation_of_cement_fact_sheet.pdf

63 https://cembureau.eu/media/uightfso/16272-narrative-towards-zero-carbon-fuels-for-cement-manufacture_view-cement-sector.pdf

64 <https://www.e-asct.org/journal/view.html?uid=1837&vmd=Full>

65 Activity report (pg. 6-7), Cembureau, 2020. <https://cembureau.eu/media/m2ugw54y/cembureau-2020-activity-report.pdf>

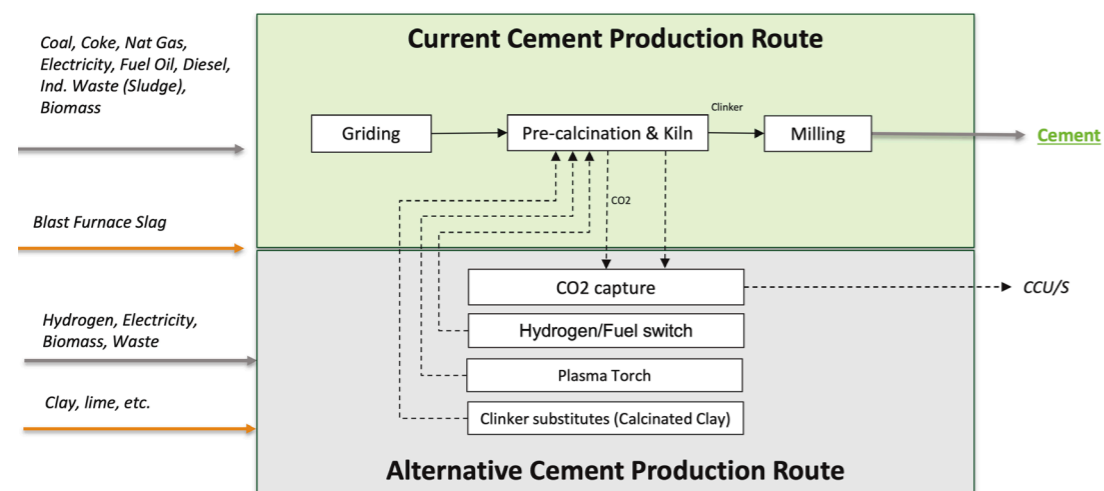

Figure 8. Cement current and alternative production routes in TIMES-BE (simplified).

Lime

Lime production has a similar structure to the production of cement. The raw material is crushed and then calcinated (1400°C) to produce quicklime. In the final hydration steps, hydrated quicklime and limewater are produced. Limestone is used in several applications, from steel to construction and agriculture. The calcination of limestone (CaCO_3) to produce lime (CaO) results in unavoidable process emissions, which account for 1/3 of the lime production emissions. The remaining emissions are due to the combustion of fuels needed to produce the high-temperature heat required by the process, which currently relies 90% on fossil fuels⁶⁶. In TIMES-BE, the production of lime is represented in a two-step process. First the raw material is calcinated - this process consumes all the heat - and then the finishing part, which consumes only electricity. In the model, the production of lime in the current case requires nearly 5 GJ/t_{lime} and emits about 1.2 tCO₂/t_{lime}. In TIMES-BE, the sector has the option to be decarbonized by including the use of hydrogen and electricity in the kiln, for the combustion emissions, and using carbon capture for the process emissions. For instance, recently, the lime sector has joined efforts with the chemical sector to test the use of CCUS technologies⁶⁷.

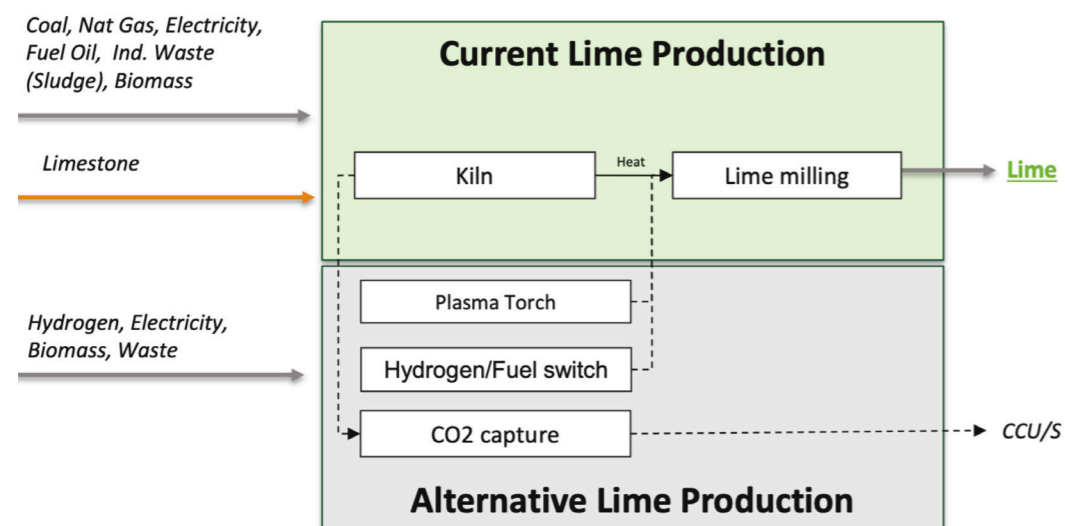

Figure 9. Lime current and alternative production routes in TIMES-BE (simplified).

Glass

There are three main glass products with different energy intensities and process-related emissions: fibreglass, container glass and flat glass. Container glass is used in several applications, from beverages and food packing to perfumes and pharmaceuticals, and its recycling rate is high. The European Container Glass Federation estimates a recycling rate higher than 90% in Belgium⁶⁸. Therefore, there is a high use of cullet to produce glass, which leads to less energy consumption and process emissions as less raw materials (carbonates) are used in the production. In TIMES-BE, container glass has a specific energy consumption of 6.4 GJ/t.

Flat glass supposes a similar process as container glass, although the last steps are different, especially in forming and cooling. These particular differences increase the specific energy consumption with respect to container glass by 15-50%⁶⁹ depending on the technology. In TIMES-BE, the energy intensity of flat glass is set at 8.5 GJ/t. Finally, fibreglass is a more complicated process as it requires more energy for the special fibre forming required to produce fibre yarns or mats, with a total energy consumption of 11.5 GJ/t. Additionally, since it is a more sensitive product, the process cannot be fully electrified due to technical limitations⁷⁰. In TIMES, these three processes are characterized as a single process, with the energy intensity of each one as well as the energy mix, which is currently dominated by natural gas. Similar to other sectors where process emissions are relevant, TIMES-BE differentiates process emissions from combustion emissions. This allows the model to explore decarbonization options for heat demand, such as electric boosting or the use of clean molecules, while for the process emissions the sector relies more on novel material mixes or CCUS.

Besides the benefits of the use of better glass (i.e., building glazing, Building Integrated Photo Voltaic), Glass for Europe identified three routes to reduce CO₂ emissions, starting with flat glass recycling (-7%) and switching to carbon-neutral powered furnaces (up to -75%) and CCUS (up to -85%)⁷¹. Another case is found in Germany, where the glass industry is exploring the use of hydrogen to replace the use of natural gas in furnaces through the HyGlass project⁷². Thus, considering the options identified by the glass industry, TIMES-BE covers these decarbonization strategies for each glass product.

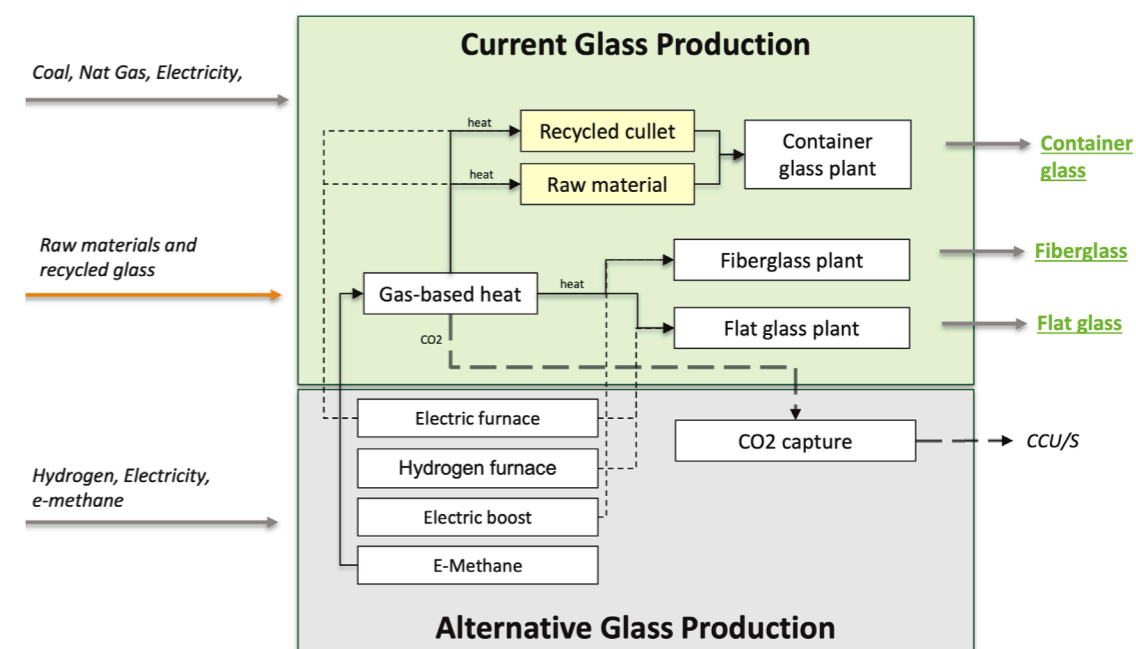

Figure 10. Glass current and alternative production routes in TIMES-BE (simplified).

Bricks

Bricks are an important material in construction, and with an increasing population, the need for this material is not expected to fall. Nonetheless, it is possible that in the future, when a circular economy emerges, the reuse of bricks might have an impact on local production. This is not covered in TIMES-BE, and the assumption of constant industrial activity still holds. We differentiate between regular and façade bricks; each has a different energy intensity, as façade bricks require more energy due to quality and finishing. In TIMES-BE, façade bricks have a specific energy intensity (SEC) of 2.95 GJ/t, while the SEC of regular bricks is 2.4 GJ/t. These values are in line with other reports⁷³⁻⁷⁴. The production of bricks is divided in TIMES-BE to reflect the two levels of temperature that are used. Firstly, the clay must be prepared and dried, which usually requires temperatures of 75-90°C (low-temperature heat). Secondly, once ready and shaped, bricks go to the furnace where continuous firing will take place at 1000-1300°C (high-temperature heat). Then the bricks are finished and packed. Process emissions in the production of bricks come from the chemical reactions of carbonates which depend on the mix of raw materials. These bricks process related emissions are approximately 0.05-0.07tCO₂/t⁷⁵, which accounts for nearly 27% of the total emissions from brick production.

66 A Competitive and Efficient Lime Industry (pg.11), EULA. https://www.eula.eu/wp-content/uploads/2019/02/A-Competitive-and-Efficient-Lime-Industry-Summary_0.pdf
 67 <https://www.airliquide.com/group/press-releases-news/2022-05-09/air-liquide-and-lhoist-join-forces-launch-first-its-kind-decarbonization-project-lime-production>
 68 https://feve.org/glass_recycling_stats_2018/

69 Energy Efficiency Improvement and Cost Saving Opportunities for the Glass Industry (Table 7), Ernst Worrell et al, 2008. <https://www.osti.gov/biblio/927883>
 70 Decarbonisation Options For The Dutch Glass Fibre Industry (pg. 17), TNO, 2019. https://www.pbl.nl/sites/default/files/downloads/pbl-2019-decarbonisation-options-for-the-dutch-glass-fibre-industry_3721.pdf
 71 Flat glass in climate-neutral Europe (pf.20-21), Glass for Europe, 2020. <https://glassforeurope.com/wp-content/uploads/2020/01/flat-glass-climate-neutral-europe.pdf>
 72 <https://www.bvglas.de/en/dekarbonisierung/hyglass-wasserstoffeinsatz-in-der-glasindustrie/>
 73 BRICK Sustainability Report (pg. 8), BRICK, 2016. <https://www.brick.org.uk/admin/resources/brick-sustainability-report-2016-1.pdf>
 74 Brick by brick (Table 1), SDC et al, <https://www.shareweb.ch/site/EI/Documents/PSD/Topics/Social%20Aspects%20of%20Work/Brick%20by%20Brick%20-%20The%20Herculean%20Task%20of%20Cleaning%20up%20the%20Asian%20Brick%20Industry.pdf>
 75 Decarbonization Options For The Dutch Ceramic Industry (Figure 8), TNO, 2019. <https://www.pbl.nl/sites/default/files/downloads/pbl-2020->

The division of temperature levels allows us to provide alternatives for low-temperature heat, such as industrial heat pumps. In the case of high-temperature production alternatives for the firing, TIMES-BE includes hydrogen, electricity (i.e., heaters and microwaves) and green methane solutions. If one of these solutions were implemented, the sector would reach a maximum decarbonization of 73%, as the remaining emissions are process related. Hence, the deployment of CCUS technologies is necessary to reach higher emission reduction targets. Certainly, this is true as the European Ceramic Industry Association aims to reach climate neutrality by 2050 by fuel switching (i.e., hydrogen, biofuels and electricity), increasing efficiency in the manufacturing process, CCUS, reducing carbon-containing additives, reducing the carbon content of clay mixes and using carbon removal and offsetting measures⁷⁶.

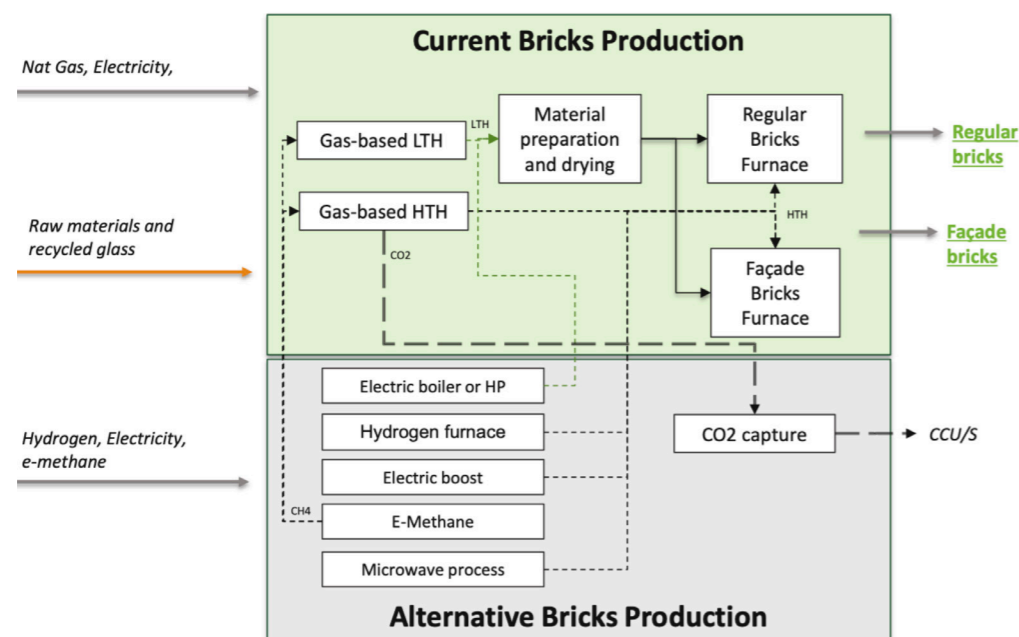

Figure 11. Bricks current and alternative production routes in TIMES-BE (simplified).

Other Non-Metallic Mineral Industries

The remaining energy consumption of non-metallic minerals is represented in Other Non-Metallic Mineral Industries. These industries are not modelled in detail as data are scarcely available. Therefore, this part of the industry is modelled by fixing a given energy demand (see Table 5), which is met by providing machine drive and high-temperature heat. Most of the energy used in Other Non-Metallic Minerals Industries is used to produce high-temperature heat. To decarbonize the heat demand of this sector, there are several alternatives which include clean molecules and electric furnaces.

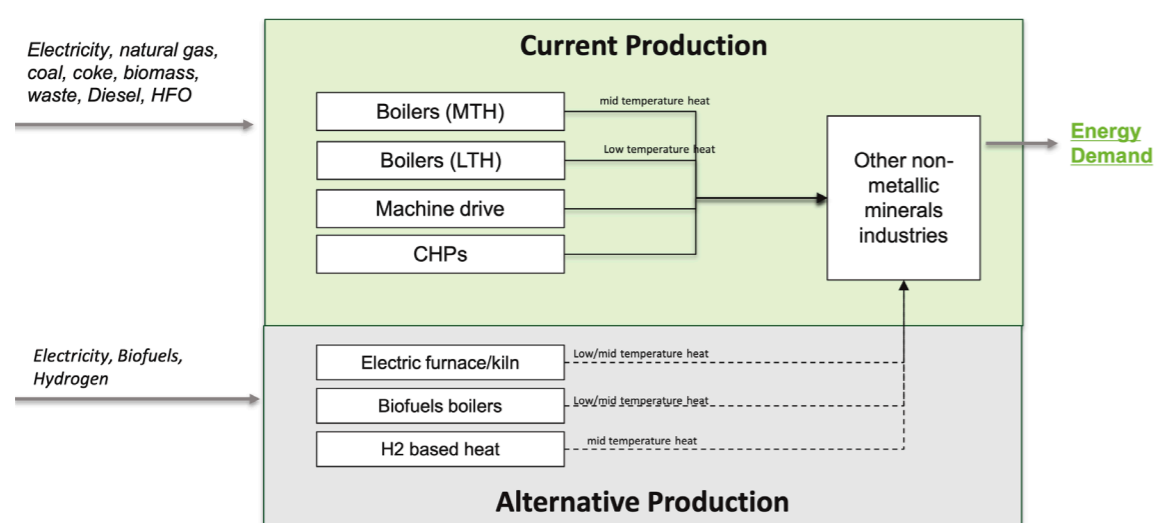

Figure 12. Other Non-Metallic Minerals Industries' current and alternative production routes in TIMES-BE (simplified).

4.2.4 Non-Ferrous Metals

Non-Ferrous Metals include copper, zinc and Other Non-Ferrous Metals Industries (NFM). This sector is responsible for 2.8% (3.4 TWh) of the industrial final energy demand and 0.6 MtCO₂. A large part of the emissions is related to the combustion of fuels. In TIMES-BE, the production of copper and zinc requires 0.8 TWh and 1.1 TWh, respectively. The final energy demand which is not included in the production of these products (1.5 TWh) is allocated to Other Non-Ferrous Metals Industries and modelled as energy consumption. In TIMES-BE, the production route for these products can be replaced by future alternatives, which are modelled separately, as can be seen in Table 9. In this section, we describe the structure of the sector as well as the decarbonization strategies and their possible implications.

	Current Technologies	Fuel replacement	Hydrogen/Molecules	Electrification	CCU/S
Copper	Copper electrolytic refining (anode furnace)		H ₂ anode furnace		
Zinc	Purification/Melting/Casting	Biogas burners		Electric burners	Amine absorption
Other Non-Ferrous	Energy demand (High/Low-Temperature Heat, machine drive)	Biogas burners	H ₂ -based heaters for high and low-temperature heat	Electric heaters for high and low-temperature heat	

Table 9. Emission reduction options for the non-ferrous metals sector by decarbonization strategy.

Copper

The production of refined copper is done through the hydrometallurgy process, which involves copper oxide ore through leaching and solvent extraction, prior to the main process. The main step in the copper hydrometallurgy process is electrowinning, where an electric current is applied to dissolve the copper from the anode onto the cathode as pure copper metal. Additionally, copper scrap and concentrated copper are used in the smelting process, before the fire and electrolytic refining. As the production of copper has a clear differentiation between the thermal and the electric driven processes, in TIMES-BE this is modelled into two processes - one consuming mostly electricity and one consuming heat. The entire process has a specific energy consumption of 7.9 GJ/t of copper⁷⁷, of which 54% is covered by electricity. In TIMES-BE, hydrogen can produce the process heat required but also as a reducing agent. Hydrogen used as a reducing agent to replace natural gas will increase the energy demand for the reduction by 20.5%⁷⁸. The use of hydrogen for the production of copper anodes is already being investigated in a pilot project by Aurubis in Hamburg, Germany⁷⁹.

Zinc

Zinc production in Belgium is done using the electrolysis smelting route. This process consists of roasting, leaching, electrolysis, smelting and casting, and replaced the imperial smelting process based on fossil fuels (i.e., coke, natural gas). In TIMES-BE, the production of zinc has a specific energy consumption of 15.5 GJ/t of zinc. This process is divided into three steps: roasting and leaching consume 9% (1.4 GJ/t_{zinc}), where several chemical reactions take place at 400-900°C. Next, the purification and electrolysis of the leach liquor consume 76% (11.8 GJ/t_{zinc}) to produce pure zinc which is finally melted and cast as a final product. As the production of zinc has been highly electrified, the emission reduction options in TIMES-BE focus on the heat used in the roasting and melting steps by replacing natural gas with clean molecules or biogas. Nevertheless, as nearly 66% of the direct CO₂ emissions are related to the carbon embodied in the zinc concentrates, CCUS technologies are needed to reach high emission reduction levels, which poses a big challenge as the CO₂ concentration in the flue gasses is very low. On the other hand, zinc plants have an excess of heat, which might be used in carbon capture units.

Other Non-Ferrous Metals Industries

The energy that is not consumed by the production of copper and zinc is allocated to the Other Non-Ferrous Metals Industries. This represents 44% (1.5 TWh) of the total consumption reported for the sector in the Belgian energy balance. 62% (0.9 TWh) of the energy consumed in the sub-sector comes from natural gas, 33% (0.5 TWh) from electricity (i.e., machine drive) and the remaining 5% from other fossil fuels. As most of the final energy consumption can be assumed to be used for the production of heat and considering that about 55% and 35% are for high-temperature and low-temperature heat, respectively, the emission reduction options cover electrification, biofuels and clean molecules. As the industry works with metallic products, it is expected that the heat gets in contact with the product; therefore, heat pumps are not considered for this sub-sector. Instead, electric furnaces and heaters might be used.

⁷⁷ In line with Energy efficient copper electrowinning and direct deposition on carbon nanotube film from industrial wastewaters, Pyry-MikkoHannula et al., 2019. <https://doi.org/10.1016/j.jclepro.2018.10.097>

⁷⁸ Decarbonizing copper production by power-to-hydrogen: A techno-economic analysis, Røben et al., 2021. <https://doi.org/10.1016/j.jclepro.2021.127191>

⁷⁹ <https://www.aurubis.com/en/media/press-releases/press-releases-2021/aurubis-first-copper-anodes-produced-with-hydrogen>

4.2.5 Food and beverages

The food and beverage industry in Belgium is distributed across the country, with some differences between Flanders and Wallonia due to the main products in both regions. In TIMES-BE, to represent the national food industry, which is responsible for 16% (19.1 TWh) of the final energy consumption in the industry, we divided it into the Flanders and Wallonia food industries by using the regional energy balances. As such, Flanders accounts for 66% (12.6 TWh) of the energy consumption in the sector while Wallonia for the remaining 34% (6.5 TWh). About 20% of the energy consumed in the sector is currently supplied by CHPs, which produce part of the heat that is consumed by the sector.

The food sector then is characterized by electricity (38%) and heat (62%) demand which remains constant throughout the modelling period. Moreover, the available biomass as a by-product of the sector is also represented, which is mostly consumed on-site to generate heat and is not traded with other sectors. Almost 60% of the heat demand in the sector is below 100°C⁸⁰, which makes it a good candidate to deploy heat pumps. Nonetheless, to decarbonize heat above 200°C, other alternatives such as electric heaters or hydrogen boilers might be used.

4.2.6 Pulp and paper

The paper industry is the fifth most energy-intensive industry in Belgium, accounting for 6.5% (8.1 TWh) of the final energy demand in the industry. Paper is used in many different ways in society, from printing and graphics to packaging and case material. The type, or quality, of paper can be classified based on its final use. However, in TIMES-BE, paper is classified according to the type of pulp used to produce it. There are mainly three types of pulp, namely the mechanical pulp, chemical pulp and recovered pulp⁸¹. Thus, in TIMES-BE, each production route is composed of two steps: pulp production and paper machine, with a total average specific energy consumption of 16 GJ/t of paper. The average specific energy consumption of the sector is reduced since the production of recycled paper requires almost half of the energy of mechanical and chemical pulp while recycled paper represents almost 1/3 of the paper production in Belgium⁸².

In the first step, the raw material (i.e., wood, recycled paper) goes into pulp production, where electricity and heat are used to produce the different types of pulp. In this step, nearly 48% of the specific energy consumption is used. At this point, approximately 6 TWh of black liquor is produced as a by-product, which is consumed internally in the production of heat and electricity. Then, in the second step, paper is produced by removing the water content and drying the final product using steam-heated drying cylinders.

As paper production requires temperatures between 60°C and 170°C⁸³, heat pumps will most likely be able to cover the heating demand.

4.2.7 Other industries, not elsewhere specified energy consumption and non-energy demand

Other industries include transport equipment, machinery, mining and quarrying, wood and wood products, construction, textile and leather, and not elsewhere specified. These industries account for 13.7% (17.1 TWh) of the final energy consumption in the industry and are therefore modelled using a top-down approach. This is, in TIMES-BE, the total energy demand of the sector is given by the historical energy demand. However, from the final energy consumption, we estimate the heat demand, which is linked to the consumption of fossil fuels, biomass and the CHPs linked to these sectors. Thus, by differentiating the heat demand, TIMES-BE can select the most convenient technology to meet the heat demand. Additionally, only in construction and not elsewhere specified, the consumption of diesel is assigned to the off-road application. The final energy mix for each sub-sector of other industries can be seen in Figure 13.

The emission reduction strategies for these industries seek to replace the use of fossil fuels to produce heat by introducing electrification options (i.e., heat pumps, electric boilers) and the use of clean molecules (i.e., hydrogen, e-methane) as the heat required is mostly below 100°C (60% on average), and approximately 10% at 100-400°C. For off-road applications, the use of biofuels and synthetic fuels is available in the model.

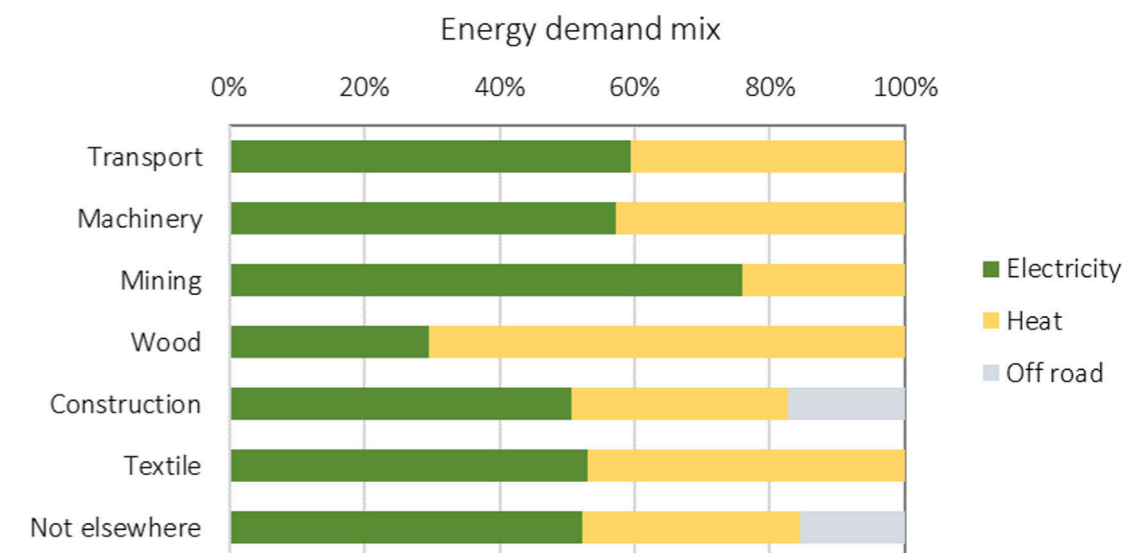

Figure 13. Energy demand mix for other industries in TIMES-BE.

Finally, the remaining non-energy demand that is not represented by the feedstock consumption of the industry is allocated to one single process that consumes 18.9 TWh, split into coal tar (2.9 TWh) and other oil products (16 TWh) such as lubricants, bitumen and other oil products reported in Eurostat's energy balance. This non-energy consumption is not included in the feedstock of the chemical sector, and is, as in other cases, assumed to remain stable up to 2050.

4.3 Transport

During the COVID-19 pandemic in 2020, consumption of this sector fell as passenger mobility was restricted and economic activity was reduced. But in 2019, the domestic transport sector in Belgium consumed 27% (103TWh) of the total final energy demand, and during that same period, it was responsible for 25.9 MtCO₂, making it one of the sectors with the highest GHG emissions, only surpassed by industry. In 2019, its emissions were 24% higher than in 1990²⁶.

Roughly one third of emissions in Belgium originate in the transport sector, especially linked to diesel consumption. On top of that, because of economic activity in the ports of Antwerp and Ghent, Belgium is one of the most road-dense regions in Europe⁸⁴. Thus, the transport sector faces an enormous challenge to reduce GHG emissions. And since the main decarbonization options for the sector are electricity or hydrogen, it is expected that the power sector will be heavily impacted by such transformation.

The transport sector as here considered embeds all national and international transport, both passenger and freight. However, international transport emissions are not accounted for in the Belgian GHG inventory and, therefore, are not part of the national emissions in TIMES-BE. The structure resembles the Eurostat energy balance, with different subsectors (i.e., rail, domestic aviation, inland navigation and road). In the BE TIMES model, road transport is split into passenger cars, buses, freight and motorcycles. Within passenger cars, four categories are defined based on driving habits - Commuting, Non-Commuting, Long Distance and Short Distance). To represent the distribution of charging facilities for EVs between charging at home and charging in public spaces such as parking places, in TIMES-BE, passenger cars have the option to use chargers in the residential sector and chargers in the commercial sector as part of the optimisation (see Figure 14).

In TIMES-BE, road and rail transport are defined with an energy service demand (billion passenger-km). The emission reduction alternatives, by drivetrain, that are included in TIMES-BE to reduce CO₂ emissions in each category of the transport sector can be seen in Figure 15.

80 Residential Heat Supply by Waste-Heat Re-Use: Sources, Supply Potential and Demand Coverage—A Case Study (Figure 1), Wolfgang et al., 2017.

<https://www.mdpi.com/2071-1050/9/2/250>

81 Product Classification And Its Implication On Competitiveness And Carbon Leakage (Figure 1), Climate Strategies, 2011.

<https://climatestrategies.org/wp-content/uploads/2014/11/pulp-paper-and-paperboard-report-cs-final-with-executive-summary.pdf>

82 Annual statistics (pg. 4), COBELPA, 2014. <http://www.cobelpa.be/pdf/stats2014.pdf>

83 Potential of Solar Energy Utilization for Process Heating in Paper Industry in India: A Preliminary Assessment (Table 2), Ashish K.Sharma et al., 2015.

<https://doi.org/10.1016/j.egypro.2015.11.486>

84 <https://ec.europa.eu/eurostat/web/products-eurostat-news/-/ddn-20200528-1>

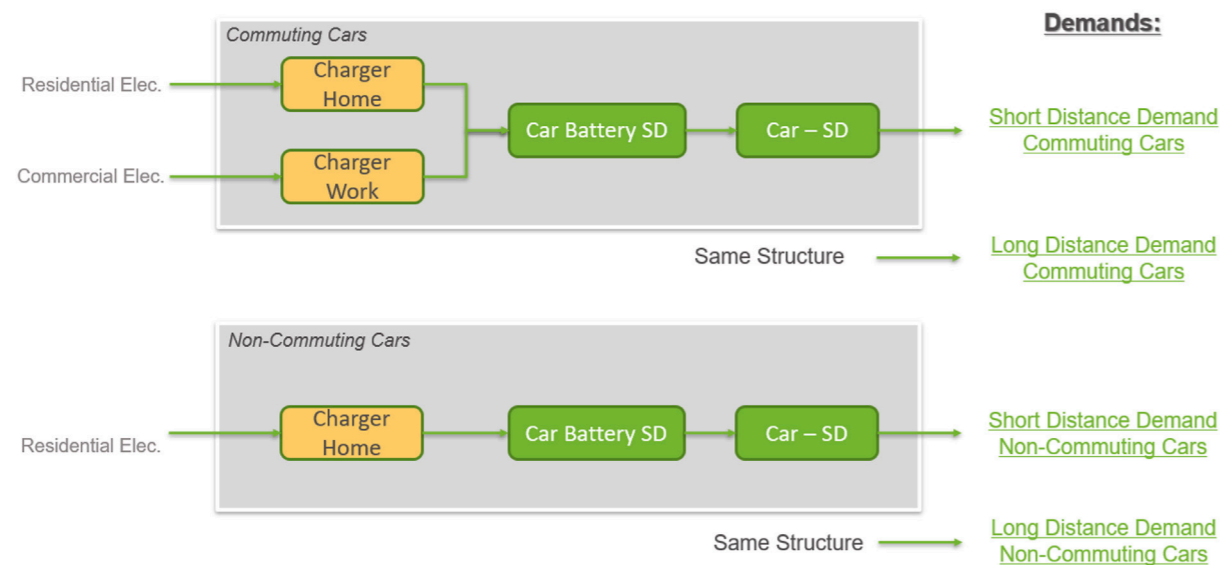

Figure 14. Scheme of charging options for passenger EVs in TIMES-BE.

The demand for road transport was built in two ways. For passenger cars, an hourly demand profile was created for the four different categories. When it comes to buses (both urban and intercity), trucks and motorcycles, demand was defined at the annual level. Demand projections for 2050 were taken from TML's TREMOVE model, which foresees a demand increase for all passenger cars, buses and motorcycles of around 11-14%, and nearly 29% for trucks.

Subsector	Category	Unit	2020	2030	2040	2050
Aviation	International aviation	TWh	17.23	18.61	19.81	21.00
	Domestic aviation	TWh	0.05	0.05	0.06	0.06
Navigation	Inland navigation	TWh	2.13	2.33	2.45	2.58
	International bunkers	TWh	74.17	81.11	85.40	89.69
Road	Bus - Coach/Intercity	Pkm*10 ⁹	3.71	3.87	3.97	4.06
	Bus urban	Pkm*10 ⁹	14.80	15.34	15.64	15.94
	Commuting Car - Long Distance	Pkm*10 ⁹	52.01	53.85	55.06	55.67
	Commuting Car - Short Distance	Pkm*10 ⁹	13.00	13.46	13.76	13.92
	Freight	Tkm*10 ⁹	33.47	36.07	38.51	40.94
	Motorcycles	Pkm*10 ⁹	1.41	1.67	1.97	2.27
Rail	Non-Commuting Car - Long Distance	Pkm*10 ⁹	40.87	42.31	43.26	43.74
	Non-Commuting Car - Short Distance	Pkm*10 ⁹	10.22	10.58	10.82	10.94
Rail	Rail Freight	Tkm*10 ⁹	8.89	10.77	12.38	13.99
	Passengers Light	Pkm*10 ⁹	1.13	1.22	1.28	1.34
	Passengers Heavy	Pkm*10 ⁹	10.75	11.13	11.47	11.81

Table 10. Demand projection for the transport sector by category in TIMES-BE.

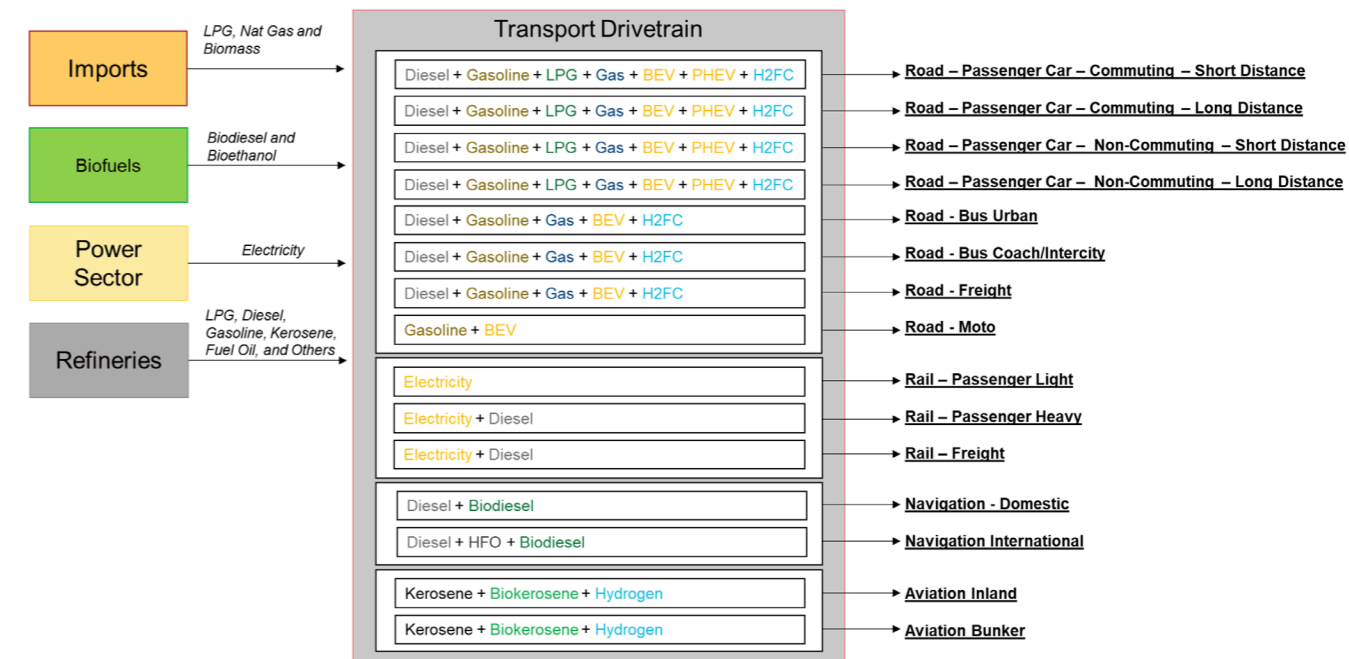

Figure 15. Decarbonization options for the transport sector by drivetrain in TIMES-BE.

4.4 Residential

The residential sector in Belgium accounts for 24.1% (91.4 TWh) of the final energy consumption. Most of the demand of this sector is met with natural gas 41.3% (37.8 TWh), diesel 26.9% (24.6 TWh) and electricity 20.1% (18.4 TWh)⁸⁵. This strong dependency on fossil fuels (nearly 78%) results in 16 MtCO₂ emissions, which is 19.4% of total CO₂ emissions⁸⁶. Therefore, decarbonizing the residential sector is fundamental to reaching deep decarbonization of the economy. This is why the European Commission is promoting and emphasising the need for renovation and higher energy standards for new buildings, as well as moving away from fossil-based technologies such as gas or liquid fossil fuels boilers, as currently 80% of the energy consumed in buildings in Europe is used for heating, cooling and domestic hot water⁸⁷.

In TIMES-BE, the residential sector has nine service demands: space heating, space cooling, water heating, lighting, cooking, refrigeration, clothes washing/drying, dishwashing and other electric demand. Additionally, some service demands are further divided into more categories depending on the age of the building⁸⁸ (Existing: built before 2006, Intermediate: built between 2006 and 2014, and New: built from 2015 onwards) and the type of household⁸⁹ (i.e., Urban, Rural and Multifamily house). These subdivisions generate a total of nine categories for space heating, space cooling and water heating. Therefore, TIMES-BE has a total of 34 final service demands for the residential sector. Demands of the residential sector are shown in Table 11, which are driven by population growth⁹⁰. The demand for space heating in Table 11 takes into account the increase in space heating demand due to new houses and apartments being built (+19 TWh), as well as the reduction of demand for existing buildings due to demolition or deep renovation (-13 TWh), which leads to a total increase of 6TWh. Here, it is important to highlight that energy savings due to renovation are not considered in the space heating demand, as this is endogenously decided by the model. In TIMES-BE, renovation and insulation are incorporated to simulate the decrease in energy consumption due to the renovation of the building stock and due to an increase in insulation level. Thus, for Existing and Intermediate buildings, the model can invest in technologies representing roof, wall and glass insulation. There are three technologies for each insulation option to represent the difference in cost and insulation level that can be implemented. Table 12 shows the energy savings that can be obtained from better insulation in existing houses in Belgium, which are differentiated by the investment needed. Thus, the average household might be able to annually save on average 6-14% (0.6-1.3 MWh) of the energy used in space heating in existing houses with insulation. Here, it is important to mention that the stock of existing houses declines over time, as new and more efficient houses are built. These new houses are not subject to renovation measures in TIMES-BE.

85 Eurostat energy balance 2019.

86 <https://climat.be/doc/nir-2021-150421.pdf>

87 https://ec.europa.eu/commission/presscorner/detail/en/IP_21_6683

88 Based on the EPC databank. <https://documentserver.uhasselt.be/handle/1942/18940>

89 Based on Statbel data on buildings. http://statbel.fgov.be/nl/statistieken/cijfers/economie/bouw_industrie/gebouwenpark/

End demand	Current energy mix	Current demand [TWh]	2030 demand [TWh]	2040 demand [TWh]	2050 demand [TWh]	Driver
Space heating ⁹⁰	Biomass (8%), Coal (2%), Electricity (4%), Natural Gas (45%), Diesel (38%)	36.53	41.64	42.06	44.39	Population growth, according to Federal Planning Bureau projections ⁹¹ . Adjusted by future temperature, and warm and cold days.
Space cooling	Electricity (100%)	0.31	0.48	0.53	0.64	
Water heating	Biomass (5%), Electricity (15%), Natural Gas (46%), Diesel (38%)	8.86	8.86	8.69	8.86	
Lighting	Electricity (100%)	2.08	2.19	2.28	2.33	Population growth, according to Federal Planning Bureau projections.
Cooking	Biomass (1%), Electricity (38%), Natural Gas (50%), LPG (11%)	3.64	3.89	4.03	4.11	
Refrigeration	Electricity (100%)	3.97	4.22	4.36	4.47	
Clothes washing	Electricity (100%)	0.78	0.83	0.86	0.89	
Clothes drying	Electricity (100%)	1.19	1.19	1.19	1.19	
Dishwashing	Electricity (100%)	0.47	0.50	0.53	0.56	
Other electric	Electricity (100%)	5.47	5.83	6.03	6.19	

Table 11. Demand projection for the residential sector by service end demand in TIMES-BE.

The residential sector has a clearly defined hourly electricity demand profile that reflects behaviour patterns and weather conditions. This is also the case for the consumption of natural gas, which accounts for nearly 40% of the total final energy consumption of the sector. Therefore, we defined hourly profiles for all service demands of the residential sector, which were developed as part of the BREGILAB⁹² project using the proportional input-output (or RAS) methodology⁹³.

	Unit	2014	2016	2020	2025	2030	2035	2040	2045	2050
Maximum	TWh	9.48	9.48	9.24	9.00	8.76	8.52	8.28	8.04	7.79
Average	TWh	2.38	2.38	2.38	2.38	2.38	2.38	2.38	2.38	2.38
Minimum	TWh	0.19	0.19	0.19	0.19	0.19	0.19	0.19	0.19	0.19

Table 12. Space heating energy savings from insulation in residential sector existing houses in TIMES-BE.

In addition to many fossil fuels-based processes, such as gas-fired boilers, gas stoves and gas-fuelled heat pumps, the other possible processes available in the model are:

- Wood pellet boiler
- Electric radiator
- Electric boiler
- Air heat pump (both with and without heating/cooling option)
- The advanced air heat pump (both with and without heating/cooling option)

⁹⁰ Space heating, space cooling and water heating demands refer to the end use. The final energy consumption to meet these demands reflects the efficiency of the technology used to this end. This demand refers to the baseline and doesn't include energy efficiency gains from renovations and insulation.

⁹¹ https://www.plan.be/databases/data-36-en-energy_outlook_for_belgium_towards_2050_october_2017_edition_statistical_annex

⁹² <https://www.energyville.be/en/research/bregilab-support-research-development-renewable-energy-belgian-electricity-grid>

⁹³ BACHARACH, Michael: (1970) Biproportional Matrices and Input-Output Change. Cambridge University Press, Cambridge.

- The ground heat pump (both with and without heating/cooling option)
- District heating (DH) heat exchanger
- Solar collector (with electric, gas and diesel backup)
- Biomass boiler
- Solar collector with electric/gas/oil backup
- Electric cooking stoves

Finally, other service end demands that are fully electrified, such as lighting, space cooling and refrigeration, have the option to invest in more efficient technologies to reduce the total final energy consumption of the sector. The introduction of highly efficient heat pumps lowers the overall energy consumption, but can increase the peak electricity consumption. TIMES-BE has several options to cope with such peaks, as can be seen in Section 5.1.

4.5 Commercial

Similar to the residential sector, the current energy consumption of the commercial and public services sector is dominated by electricity and natural gas – 40% (21.6 TWh) and 41% (22.1 TWh) respectively. Diesel accounts for 15% (7.9 TWh), which is used for diesel engine generators and boilers. As such, the effort to reduce direct CO₂ emissions in this sector must be directed to replace fossil fuels used for space and water heating and to reduce the reliance on diesel engine generators as a backup for electricity supply and movable uses (i.e., cultural and music festivals far from the distribution grid). Additionally, energy efficiency measures can reduce the electricity intensity of the sector, and then the impact on the power sector.

As was done for the residential sector, the commercial sector in TIMES-BE is also subdivided into eight energy service demand categories: space heating, space cooling, water heating, cooking, lighting, refrigeration, public lighting and other electric applications. To differentiate the heat needs based on the characteristics of buildings, space heating and cooling, and water heating, are then characterized per type of building, depending on the size of the building (small and large). In total, therefore, there are eleven final energy service demands for this sector. As is the case for the residential sector, the hourly profiles were obtained from the results of the BREGILAB project. The projected demand is shown in Table 13, and – in line with the residential sector – the energy savings due to insulation, are shown in Table 14.

End demand	Currently satisfied with	Current demand [TWh]	2030 demand [TWh]	2040 demand [TWh]	2050 demand [TWh]	Source
Space heating	Biomass (<1%), Electricity (20%), Natural Gas (51%), Diesel (27%)	22.51	23.37	24.51	25.77	Study "Towards 100% renewable energy in Belgium by 2050" ⁹⁴
Space cooling	Electricity (100%)	2.36	2.68	2.95	3.26	
Water heating	Electricity (30%), Natural Gas (43%), LPG (4%), Diesel (22%)	3.18	3.44	3.70	3.98	
Lighting	Electricity (100%)	6.85	7.43	7.98	8.59	
Cooking	Electricity (41%), Natural Gas (50%), LPG (9%)	2.71	2.98	3.21	3.45	
Refrigeration	Electricity (100%)	3.17	3.44	3.69	3.98	
Public Lighting	Electricity (100%)	0.85	0.89	0.93	0.98	
Other electric	Electricity (100%)	5.00	5.41	5.63	5.86	

Table 13. Demand projection for the commercial sector by service end demand in TIMES-BE.

	Unit	2014	2016	2020	2025	2030	2035	2040	2045	2050
Maximum	TWh	1.88	1.93	1.92	1.91	1.94	1.98	2.03	2.08	2.14
Average	TWh	1.33	1.35	1.35	1.34	1.36	1.39	1.42	1.46	1.50
Minimum	TWh	0.77	0.77	0.77	0.77	0.78	0.80	0.81	0.84	0.86

Table 14. Space heating energy savings from insulation in the commercial and public sector in TIMES-BE.

⁹⁴ <https://energie.wallonie.be/servlet/Repository/130419-backcasting-finalreport.pdf?ID=28161>

Similar to the residential sector, an effort to reduce direct CO₂ emissions often boils down to decarbonizing the supply of useful heat within the sector. For that purpose, the same alternatives used in the residential sector are available for the commercial sector. However, due to the larger scale of installations, this sector can in certain cases have access to lower cost per energy technology unit. The emission reduction options are the following:

- Electric boiler/radiator
- Electric heat pump (air/air advanced/ground), both with and without a cooling option
- Gas boiler (simple/condensing), both with and without hot water option
- Gas HP (Air), both with and without cooling option
- District heating, with hot water option
- Solar collector with electric/diesel/gas backup
- Wood/pellets boiler
- Electric air conditioner (both room and centralized)
- Electric air chiller
- Electric air fan
- Gas air conditioner (centralized)
- Biomass boiler
- Geothermal heat exchanger

4.6 Agriculture

The agriculture, forestry and fishing sector is the smallest demand sector, responsible for 2.8% (10.5 TWh) of the Belgian final energy demand and 2.7% (2.2 MtCO₂) of CO₂ total emissions. The highest energy consumption in the sector is attributed to diesel, which accounts for 41.2% (4.3 TWh), followed by natural gas at 33.3% (3.5 TWh) and electricity at 17.1% (1.8 TWh). The energy consumption profile of this sector shows the need to tackle heat production currently from natural gas and biofuels and off-road vehicles, which are almost entirely responsible for diesel consumption. Part of the heat demand is covered by CHPs, which also generate a large proportion of the electricity consumed within the sector. TIMES-BE focuses on energy-related emissions in the agriculture sector. As a consequence, non-CO₂ greenhouse gas emissions related to land use and livestock lie outside of the scope of this study.

Demand	Current mix	Current demand [TWh]	2050 demand [TWh]	source
Electric appliances	100% electricity	1.46	1.46	Eurostat
Off-road transport	96% Diesel, 4% others	1.43	1.43	
Low-temperature heat	61% liquid fossil fuels 39% natural gas	1.08	1.08	
Greenhouse heat	90% natural gas 10% biofuels	6.03	6.03	

Table 15. Demand projection for the agriculture sector by service end demand in TIMES-BE.

In TIMES-BE, the agriculture sector has four types of end demands - electric appliances, greenhouse heating, low-temperature heating and off-road vehicles. By using such a division of the sector demand, we can focus on the end demands that require non-fossil-based technologies to reduce CO₂ emissions. On the other hand, CO₂ is needed by greenhouses to enrich crops, which promotes the combustion of natural gas for heating purposes⁹⁵. The IEA estimates that, in the Netherlands alone, this technique to boost crops yields around 5-6.3 MtCO₂ every year⁹⁶.

Greenhouse and low-temperature heat.	Off-road transport
<ul style="list-style-type: none"> ▪ Biomass boiler ▪ Biomass CHP ▪ Ground heat pump (small and large size) 	<ul style="list-style-type: none"> ▪ Biofuel-based technology ▪ Electric machine with battery ▪ Cable-powered electric machine

Table 16. Decarbonization alternatives for the agriculture sector in TIMES-BE.

95 <https://www.dutchgreenhouses.com/en/technology/co2-enrichment/>
 96 Putting CO₂ to Use (pg.64), IEA, 2019.
https://iea.blob.core.windows.net/assets/50652405-26db-4c41-82dc-c23657893059/Putting_CO2_to_Use.pdf

5. Supply and transformation sectors

5.1 Fuel and material prices

Belgium relies heavily on the import of energy carriers. In addition, Belgium is an important transit country for the European energy system, particularly for oil and petroleum products⁹⁷, but also for natural gas. Table 17 shows an overview of the fuel and material price assumptions currently in place in the model.

A particularly important trend to capture is the current high natural gas price, following the rapid economic recovery after the COVID-19 pandemic and the strongly reduced Russian pipeline delivery after the start of the war in Ukraine. In this study, we therefore consider a 2022-2023 price peak of €125/MWh. In the mid-term, around 2025, natural gas prices are assumed to drop to €50/MWh, reaching a final long-term projected price of €35/MWh. The values shown in Table 17 represent the average of each milestone period - usually 5 years - as used in TIMES-BE.

Two climate constraints are implemented in the model: a net zero emission constraint in 2050, as well as an increasing CO₂ price. Without an increasing CO₂ price, the model would only choose to invest in climate friendly alternatives towards the end of the energy transition in 2050. The CO₂ prices will increase the cost of services and products based on fossil fuels, which is why we assume that by 2050 CO₂ emission will reach a price of €350/tCO₂ - an assumption in line with results from IEA and the European Commission (see Table 18). The CO₂ cost is equally applied for ETS and non-ETS sectors, and also for residential and commercial sectors where currently no CO₂ tax is in place.

Commodity	Unit	2018	2020	2025	2030	2035	2040	2045	2050	Source
Natural Gas ⁹⁸	€/MWh	27.16	33.86	72.15	38.52	35.00	35.00	35.00	35.00	EnergyVille/VITO
Coal	€/MWh	13.61	15.50	23.05	11.20	11.11	11.20	11.47	11.52	IEA ⁹⁹
Crude Oil	€/MWh	35.76	30.60	31.32	31.68	30.96	30.24	29.52	28.80	
LPG	€/MWh	73.56	68.40	43.81	44.32	43.31	42.30	41.29	40.28	Adapted from IEA ⁹⁸
Gasoline	€/MWh	43.24	29.20	38.38	38.81	37.91	37.04	36.14	35.28	
Kerosene	€/MWh	78.96	28.01	51.98	52.56	51.37	50.18	49.00	47.81	
Naphtha	€/MWh	25.88	24.12	33.84	34.24	33.44	32.65	31.90	31.10	
Diesel	€/MWh	43.78	26.28	40.61	41.08	40.14	39.24	38.30	37.37	
Fuel oil	€/MWh	25.88	13.86	22.86	23.15	22.61	22.07	21.56	21.02	
Oven coke	€/MWh	30.00	30.00	30.00	30.00	30.00	30.00	30.00	30.00	steelonthenet ¹⁰⁰
Nuclear fuel	€/MWh	1.69	1.69	1.69	1.69	1.69	1.69	1.69	1.69	ENTSO-E ¹⁰¹
Biomass	€/MWh	16.20	16.20	16.92	16.92	16.92	18.00	18.00	18.00	HRM-EU ¹⁰²
Hydrogen	€/MWh	149.87	149.87	123.39	96.91	92.38	87.84	83.30	78.77	H2IC ¹⁰³
Ammonia	€/MWh	83.12	83.12	76.19	69.26	66.91	64.56	62.21	59.85	

Table 17. Energy commodity price projections in TIMES-BE.

	Unit	2020	2025	2030	2035	2040	2045	2050	Source
CO ₂ emissions cost	€/t	50	100	150	200	250	300	350	IEA ¹⁰⁴ , EU ¹⁰⁵

Table 18. CO₂ cost projection in TIMES-BE.

97 Values from Eurostat energy balance 2019.
 98 takes into account the current energy prices after the Russia-Ukraine conflict, inflation and post COVID-19 economic impact.
 99 IEA-WEO 2021 - <https://prod.iea.org/reports/world-energy-outlook-2021>
 100 <https://www.steelonthenet.com/files/blast-furnace-coke.html>
 101 <https://2020.entsos-tyndp-scenarios.eu/fuel-commodities-and-carbon-prices/>
 102 https://heatroadmap.eu/wp-content/uploads/2020/01/HRE4_D6.1-Future-fuel-price-review.pdf
 103 Shipping sun and wind to Belgium is key in climate neutral economy. 2021.
<https://www.deme-group.com/sites/default/files/2021-01/Hydrogen%20Import%20Coalition%20Final%20Report.pdf>
 104 Net Zero by 2050 (Table 2.2), IEA, 2021. https://iea.blob.core.windows.net/assets/deebef5d-0c34-4539-9d0c-10b13d840027/NetZeroBy2050-ARoadmapfortheGlobalEnergySector_CORR.pdf
 105 SWD(2021) 612 final (pg. 149), European Commission, 2021. <https://eur-lex.europa.eu/LexUriServ/LexUriServ.do?uri=SWD:2021:0611:FIN:EN:PDF>

5.2 Maximum resource availability

Limitations on resource availabilities are taken into account in the model setup. One example is sustainable biomass. Limitations are translated into mathematical constraints in TIMES-BE, which reduces the solution space of the optimisation and, in some cases, increases the computational time. Once the constraint is binding - i.e., the solution reaches the predefined limit - TIMES-BE tries to find the next optimal solution to meet the system demand. This is why the definition of these constraints is paramount for the modelling exercise, as they can have a large impact on the final solution. The limitations imposed on TIMES-BE, are common to all scenarios and listed in Table 19.

Commodity	Unit	2020	2025	2030	2035	2040	2045	2050	Source
Biomass	TWh	13.89	13.89	13.89	13.89	13.89	13.89	13.89	Eurostat average
Municipal Solid Waste	TWh	3.67	3.67	3.67	3.67	3.67	3.67	3.67	Eurostat average
District Heating	TWh	1.21	5.20	9.20	13.54	17.87	20.89	23.91	EnergyVille own assumption
Rooftop PV	GW	104.1	104.1	104.1	104.1	104.1	104.1	104.1	BREGILAB study by EnergyVille
Onshore wind	GW	20.0	20.0	20.0	20.0	20.0	20.0	20.0	BREGILAB study by EnergyVille
Offshore wind	GW	2.26	2.26	4.60	4.60	8.00	8.00	8.00	Belgian offshore platform ¹⁰⁶

Table 19. Maximum availability of selected resources in TIMES-BE.

Where this Table 19 reflects the maximum technical potential, other external factors influence the growth rate of certain technologies. To reflect the current hurdles in the growth of onshore wind - mainly due to local acceptance - we included an annual growth constraint of 250 MW from 2020 to 2030. After 2030, this annual growth constraint is released. For offshore wind, we included a maximum deployable capacity of 4.6 GW by 2030, reflecting the exploitation of the new Princess Elisabeth zone. By 2040, the model can invest up to the full potential of 8 GW.

5.3 Electricity network assumptions

The power sector is considered to be the cornerstone of the future energy system. Not only because of the electrification of the demand, which is required to attain climate goals, but also for its role in the production of clean molecules, which strongly depends on the availability of clean electricity at low prices. Therefore, the reliability, adequacy and flexibility of the power sector all have to be carefully considered in a long-term energy transition strategy. TIMES-BE represents the power sector in such a way that it is possible to determine the future needs of the sector, as the model optimizes the sector to meet the electricity demand due to changes in the demand (i.e., EVs, heat pumps, electric furnaces, molecules production). This study is, however, not an adequacy exercise such as Elia regularly performs, which requires hour-by-hour simulations and stochasticity in electric demand and weather years to be taken into account.

TIMES-BE includes the existing power generation capacity grouped by technology, and assigns a decommissioning profile as shown in Figure 16. This is done to mirror the future needs to replace the existing capacity. Thus, the model decides which technology to install to minimize the system cost, considering the electricity demand and hourly profiles. The portfolio of technologies available for the model includes gas turbines, biomass plants, CHPs, solar PV, onshore and offshore wind, hydrogen turbines (from 2030 onwards), existing nuclear reactors and nuclear small modular reactors (available from 2045). Within the Energy Transition Fund BREGILAB project, the Belgian technical potential for rooftop PV and onshore wind was calculated by making use of the Dynamic Energy Atlas for Belgium. This geographically explicit exercise resulted in a technical potential of rooftop PV and onshore wind capacity and generation at a provincial level in Belgium, taking into account solar irradiation and wind speeds per province. The technical potential for rooftop solar PV amounts to 103,3 GW and onshore wind to 20,5 GW. This technical potential is included as the upper limit in the TIMES Be model¹⁰⁷.

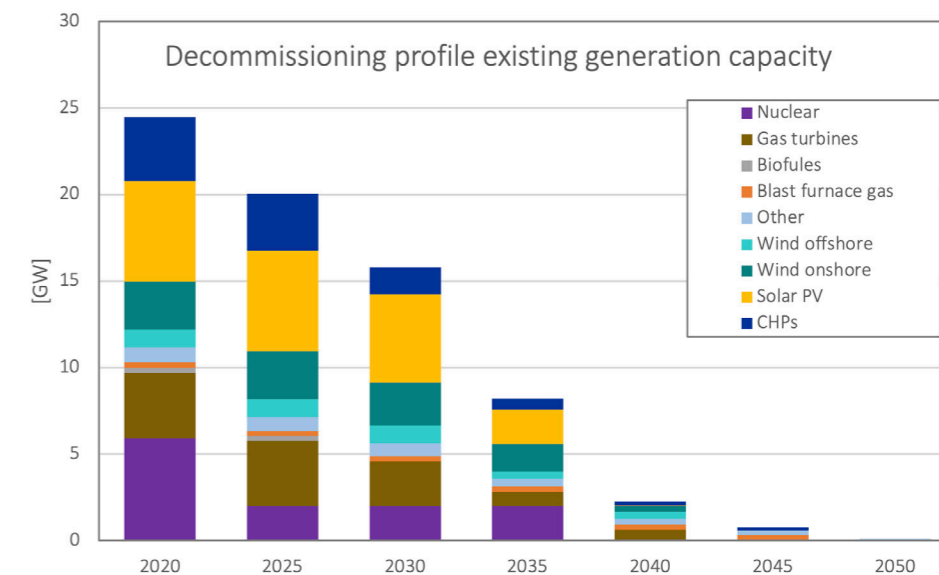

Figure 16. Decommissioning profile of existing power generation capacity in TIMES-BE.

To cope with the variability of solar and wind energy, the use of a robust interconnected grid is paramount. The European Commission identifies the relevance of the interconnection between member states to increase the share of variable renewable energy sources (VRES) and thus reduce curtailments. As such, it has set a target of 15% of interconnection capacity¹⁰⁸ for each member state by 2030¹⁰⁹. In TIMES-BE, the import and export capacities were defined according to the Ten Years Network Development Plan (TYNDP) published by ENTSO-E (European Network of Transmission System Operators for Electricity)¹¹⁰.

Since TIMES-BE's geographical representation is limited to Belgium, it was necessary to use a dispatch model developed by the KU Leuven to cover the integrated European electricity market. More specifically, the ENTSO-E (European Network of Transmission System Operators for Electricity) scenario results yield a certain capacity mix and load profile per member state. The KU Leuven dispatch model performs an optimal power flow, using these capacities and load profiles per member state, and assumes the Belgian electricity demand to vary from 0 MW up to the maximum demand in 50MW steps (a brief explanation of the methodology can be seen in ETSAP¹¹¹). The result is a price-quantity curve which enables to take into account import and export of electricity in a dynamic way.

The results of this model were integrated into TIMES-BE to represent the availability and price of imported electricity in each period (time-slice), as well as the price and willingness to consume exported electricity in other member states. The interconnection capacity is shown in Table 20. Export capacity is different to import capacity due to several technical reasons, such as the uncertainties impacting the system, as well as to be able to cope with the occurrence of any single contingency (n-1 criteria)¹¹².

	Unit	2020	2030	2040	2050	Source
Import	GW	6.5	8.9	13.0	13.0	ENTSO-E ¹⁰⁸
Export	GW	6.5	7.9	11.5	11.5	

Table 20. Interconnection capacity (import and export) for Belgium in TIMES-BE.

Besides the generation capacity, another important aspect of the power sector is the capacity of the transmission and distribution (T&D) grid to handle the peaks of demand. As TIMES-BE is not designed to have a full representation of the topology of these two networks, the model uses three different levels of voltage to link supply and demand: high voltage, medium voltage and low voltage. For the latter, we assume an investment cost to capture the future investment needed to reinforce the distribution grid. TIMES-BE works with the concept of 'copper plate', which simplifies the actual electricity flow in the grid. However, although this approach guarantees the energy balance in all periods (time-slices) and provides insight into the quantity of electricity flowing in each voltage level, it doesn't assess the flow balance and possible congestion of the grid.

¹⁰⁸ The 15% cross-border capacity ratio corresponds to the import capacity over EU countries' installed generation capacity.

¹⁰⁹ European Commission, 2018. Electricity interconnection targets [WWW Document]. URL: https://energy.ec.europa.eu/topics/infrastructure/electricity-interconnection-targets_en

¹¹⁰ ENTSO-E, 2022. TYNDP Scenarios 2022. <https://tyndp.entsoe.eu/scenarios/>

¹¹¹ Reproducing the evolution of import and export electricity price curves in Belgium, in the framework of a European power Market, VITO NV, 2022. <https://www.slideshare.net/IEA-ETSAP/reproducing-the-evolution-of-import-and-export-electricity-price-curves-in-belgium-in-the-framework-of-a-european-power-market>

¹¹² https://asset-ec.eu/wp-content/uploads/2019/05/ASSET_CACM-FBMC_FinalReport.pdf

¹⁰⁶ <https://www.belgianoffshoreplatform.be/en/>

¹⁰⁷ See How much renewable electricity can be generated within the Belgian borders? (Dynamic Energy Atlas) | EnergyVille

5.4 Molecule supply sector

The supply or transformation sector, according to the Eurostat energy balance classification, covers several processes:

- Electricity and heat production: covered in the power sector and CHPs
- Coke ovens and blast furnaces: reported in the steel sector
- Refineries and petrochemical industry
- Other transformation activities

In this section, we explain the modelling of the refineries, and include the future molecules industry that is being formed today.

5.4.1 Refineries

In refineries, complex and expensive integrated processes take place – processes that convert crude oil into finished products by heating, pressure or a catalyst. All refineries, however, share the same three basic steps: separation, conversion and treatment. In Belgium, there are four refineries with a crude oil intake capacity of 776 kbbbl/Cd¹¹³ (433 TWh). This is represented in TIMES-BE as a single, flexible process that requires heat, electricity and some fossil fuels to transform crude oil into refined products (i.e., gasoline, diesel, Naphtha). Some by-products such as refinery gas are used onsite to produce heat and electricity. Due to the geographical location of Belgium, its refineries are used to cover local demand as well as to export a big volume of refined products. In fact, in 2019, Belgium exported 378 TWh of petroleum products¹¹⁴. To represent the benefits for society of exporting such products, TIMES-BE includes the export process for each one of those products at a given price. Moreover, as the demand for diesel, gasoline and other fuels produced by refineries phases out, the refineries will be used more to export such products and to produce the feedstock used in the chemical sector (i.e., Naphtha, LPG).

	units	2014	2019	2030	2040	2050
Oil intake	TWh	376	403	339	281	222
Utilization factor	-	0.87	0.93	0.78	0.65	0.51

Table 21. Minimum crude oil intake in refineries in TIMES-BE.

The main sources of CO₂ in refineries are furnaces and boilers, utilities, catalytic crackers and hydrogen production¹¹⁵. The refineries in Belgium are responsible for 4.5 MtCO₂ emissions from the use of fossil fuels and for approximately 3.9 MtCO₂ from process emissions. The main emission reduction option for the current refinery installations is the use of CCUS. However, alternative production routes such as Fischer-Tropsch (FT) synthetic fuels from green hydrogen or biomass are also modelled in TIMES-BE.

5.4.2 Molecules

In recent years, the use of molecules, and in particular hydrogen, has been regarded as one of the pillars of the energy transition and a future carbon-neutral economy. The TIMES-BE model was adapted to represent all the future molecules' value chains from imports and local production, up to the final use. In general, TIMES-BE covers four main molecules – namely hydrogen, e-methane, methanol and ammonia. The e-methane, methanol and ammonia can be imported as such through dedicated terminals or reconverted into hydrogen, which requires additional investments and considerable energy losses, whereas pure hydrogen can be imported through cross-border pipelines. There is a representation of the main hydrogen transport grid, which assumes the development of a¹¹⁶. Large industrial hydrogen consumers and hydrogen turbines will be close to the main transport network. Conversely, other sectors (i.e., transport, commercial) will see a higher transport cost value due to distribution infrastructure, which is then represented as an additional tariff in TIMES-BE.

Local hydrogen production – both distributed and centralized – can take place through a traditional natural gas steam reformer (NG/SMR), possibly coupled to a carbon capture unit (blue H₂). Other production routes of hydrogen in the model are biomass gasification, electrolyzers (alkaline and PEM) and pyrolysis (plasma and reactor).

As hydrogen is the base for all molecules (see Figure 17), TIMES-BE includes the option to synthesize methanol, e-methane and Fischer-Tropsch fuels to be primarily used in the chemical and transport sectors. To be able to produce these molecules, there is the need for a CO₂ source, which can be either industrially captured CO₂ or CO₂ gained from the Direct Air Capture Unit (DAC).

Emissions can be reduced by capturing and using carbon (CCU) in products through methanol-to-olefins (MTO), methanol-to-aromatics (MTA) and Fischer-Tropsch. Since Belgium lacks CO₂ storage sites, yet to still account for the storage part of the CCUS strategy, all

the CO₂ to be stored is assumed to leave the country by shipping it from the ports of Antwerp and Ghent at 13.6 €/tCO₂¹¹⁷. To then account for the fact that CO₂ must be transported to those ports, a CO₂ transport tariff (€1.5/tCO₂)¹¹⁵ was included for sectors that are far from the ports, such as cement and glass (less than 180 km).

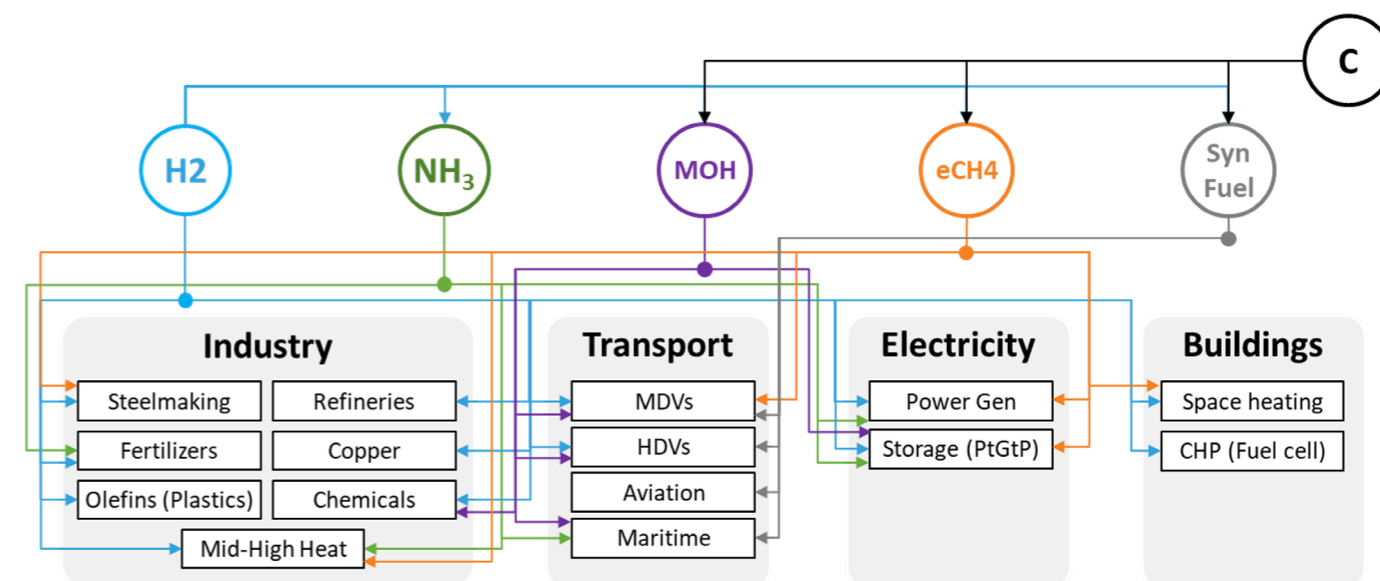

Figure 17. Simplified molecules network in TIMES-BE.

113 <https://www.concawe.eu/refineries-map/>
 114 Eurostat Belgian energy balance 2019, Export- Oil and petroleum products.
 115 <http://dx.doi.org/10.1016/j.egypro.2009.01.026>
 116 <https://ehb.eu/files/downloads/ehb-report-220428-17h00-interactive-1.pdf>

117 The Costs of CO₂ Transport Post-demonstration CCS in the EU (Table 2), ZEP.
<https://www.globalccsinstitute.com/archive/hub/publications/119811/costs-co2-transport-post-demonstration-ccs-eu.pdf>

6. Main scenarios' results

In this chapter, the main results of the 2022 model runs are presented. All of the results in this chapter can also be found on the online [PATHS 2050 Platform](#). The results in this chapter were published in September 2022. In Chapter 7, additional sensitivities are presented.

6.1 Power sector

6.1.1 Capacity and generation

Solar PV and wind play a major role under all scenarios explored, with some trade-offs depending on other restrictions imposed or lifted in the model. By 2030, under all three scenarios, solar PV increases by a factor of four - to more than 20 GW.

Between 2020 and 2030, onshore wind deployment is constraint to 250 MW additional capacity per year, reflecting barriers such as social acceptance. After 2030, onshore wind deployment can reach its full potential of 20GW (see Table 19). Offshore wind deployment before 2030 is limited to 4.6GW, reflecting the exploitation of the Princess Elisabeth zone; after 2030, offshore wind deployment in the Belgian North Sea can reach its full potential of 8GW.

Both onshore and offshore wind deployment double in capacity by 2030, and reach the limits imposed by the constraints put in the model. This result means that the techno-economic optimum for the deployment of onshore and offshore wind by 2030 is even higher than the current results.

The results of the installed power technologies in the three different scenarios are shown in Figure 18.

Under the Central Scenario, the installed electricity system capacity in Belgium needs to increase by more than a factor of five between 2020 and 2050 - from 23 GW to more than 135 GW (excl. transmission capacity). By 2050, renewable electricity sources (125 GW) represent more than 90% of the total capacity. Thus, the technical potential for renewables in Belgium is almost fully utilised: 8 GW of offshore wind, 20 GW of onshore wind and 100 GW of rooftop PV. Investments in 8 GW of e-fuel/hydrogen peak plants – in the shape of STEG plants – take place to mitigate periods of low wind and sun.

Under the Electrification Scenario, the TIMES-BE model invests in a direct connection to 16 GW of offshore wind potential outside of the Belgian North Sea, and in 6 GW of Small Nuclear Reactors (SMRs) (to be operational by 2050). This highly impacts investments in PV capacity and onshore wind. As such, PV capacity increases to 39.5 GW by 2050, which is 57 GW less than under the Central Scenario. Onshore wind capacity reaches 11.6 GW, which is 8.1 GW less than under the Central Scenario. Belgian offshore wind is slightly impacted: it reaches 7.4 GW due to the higher capacity factor of the far offshore wind farms – 60% of full load hours on a yearly basis. Furthermore, the investments in hydrogen gas turbines are impacted, as the technology is no longer selected by the model. Under this scenario, the total installed capacity grows to 83.9 GW (excl. transmission capacity), which is the lowest of all three scenarios.

Under the Clean Molecules Scenario – with an import of clean molecules at a lower cost and a limitation on carbon storage to 5 Mton/year – total installed capacity reaches 129 GW: 115 GW of renewables, and 12 GW of hydrogen turbines.

Transmission grid capacity for import and export of electricity is an exogenous assumption aligned with the ENTSO-E (European Network of Transmission System Operators for Electricity) for all three scenarios. The transmission capacity increases from a simultaneous capacity of 6,5 GW in 2020 to 13 GW from 2040 onwards. No costs are taken into account for this transmission grid increase. The transmission costs for the additional 16GW of offshore wind from outside the North Sea are, however, taken into account at 950 million €/GW, on top of the investment cost of the windmills, as mentioned in Section 3.3.

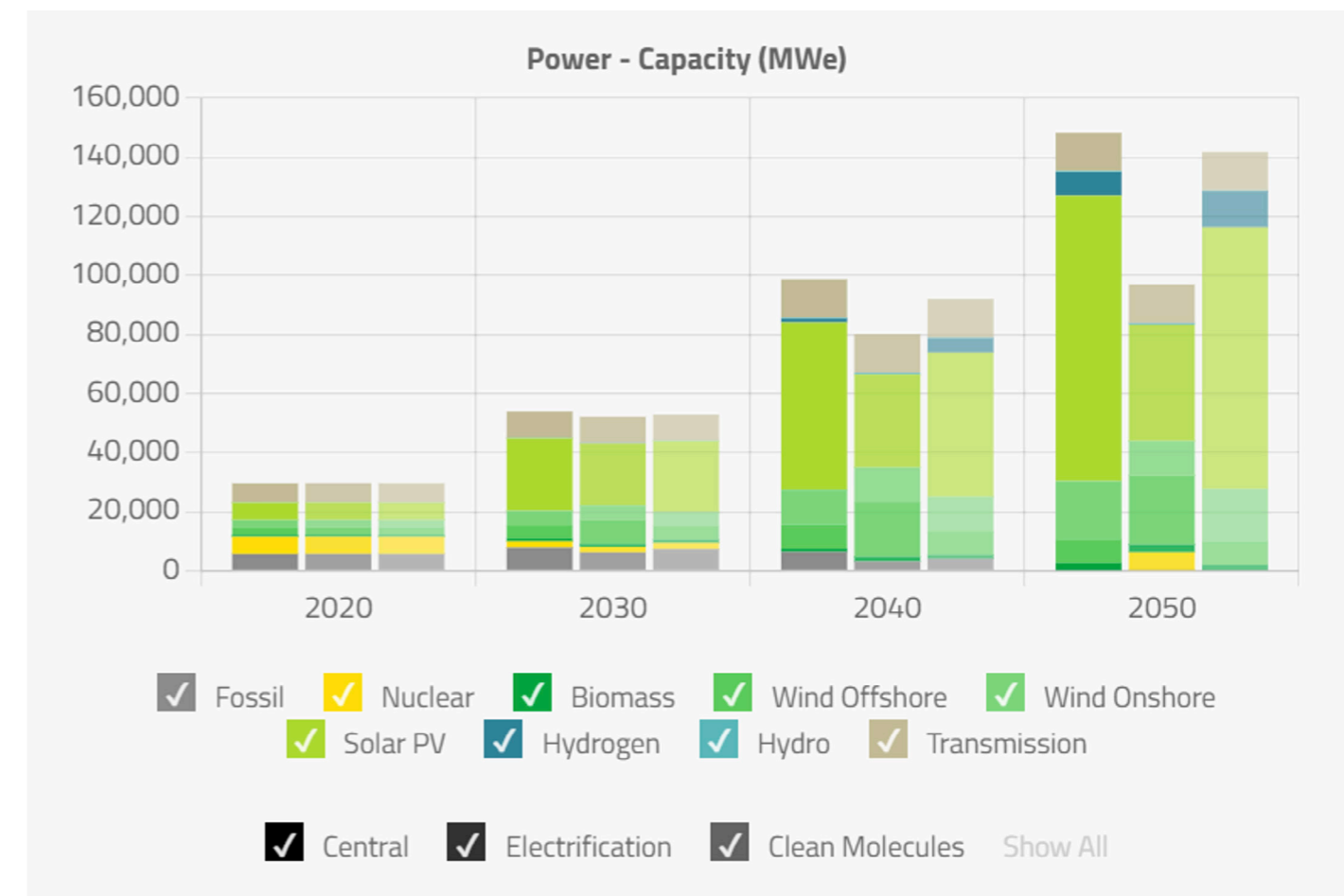

Figure 18. Power installed capacity in Central, Electrification and Clean Molecules Scenario.

Under all three scenarios, electricity generation in Belgium at least doubles by 2050 – from a current 91 TWh to more than 180 TWh (excluding net import). When it comes to the net import of electricity through the transmission grid, we see an increase under all three scenarios by 2030: from a current 3.7 TWh to more than 7 TWh. Towards 2050, the net import differs largely, depending on which scenario is considered. Note, however, that all offshore wind – including the 16GW (or 84TWh) – additional offshore wind in the Doggerbank North Sea zone under the Electrification Scenario – is categorized as 'Wind Offshore', and not as import. If this would be categorized as import, then the Electrification Scenario would have the largest import of all three scenarios.

The contribution of electricity import via transmission lines does not mean that the model only counts on import in times with low wind and solar availability in Belgium. Most of the import volumes occur when there is a lot of renewable electricity available in the neighbouring member states. Under the Central Scenario, 87% (158 TWh) is generated by renewable intermittent energy sources (wind and solar), 5% (8.5 TWh) by flexible renewables (biomass CHP and ORC) and 7.7% (13.9 TWh) by e-fuel/hydrogen turbines. By 2050, import increases to more than 30 TWh.

Under the Electrification Scenario, total electricity generation – including the generation of the additional 16 GW of direct offshore wind – amounts to 227 TWh. The Small Modular Reactors (SMRs), operational by 2050, generate almost 42 TWh of electricity, which is 18.5% of the total Belgian generation. The additional offshore wind overcompensates the decrease in production from PV and onshore wind. Renewable intermittent generation generates 179 TWh of electricity, which is 77.5% of the total generation in Belgium. Lastly, imports of electricity are reduced to 10 TWh.

Under the Clean Molecules Scenario, electricity generation in Belgium is slightly higher – with a total of 185 TWh – than under the Central Scenario, whereas for renewable production (mainly PV) we notice a decrease of 8.3 TWh. This drop in reduction is compensated by e-fuel/hydrogen gas turbines generating up to 28 TWh of electricity, which is double the amount of the generation under the Central Scenario. Moreover, electricity imports are, with their 27 TWh, slightly lower than under the Central Scenario.

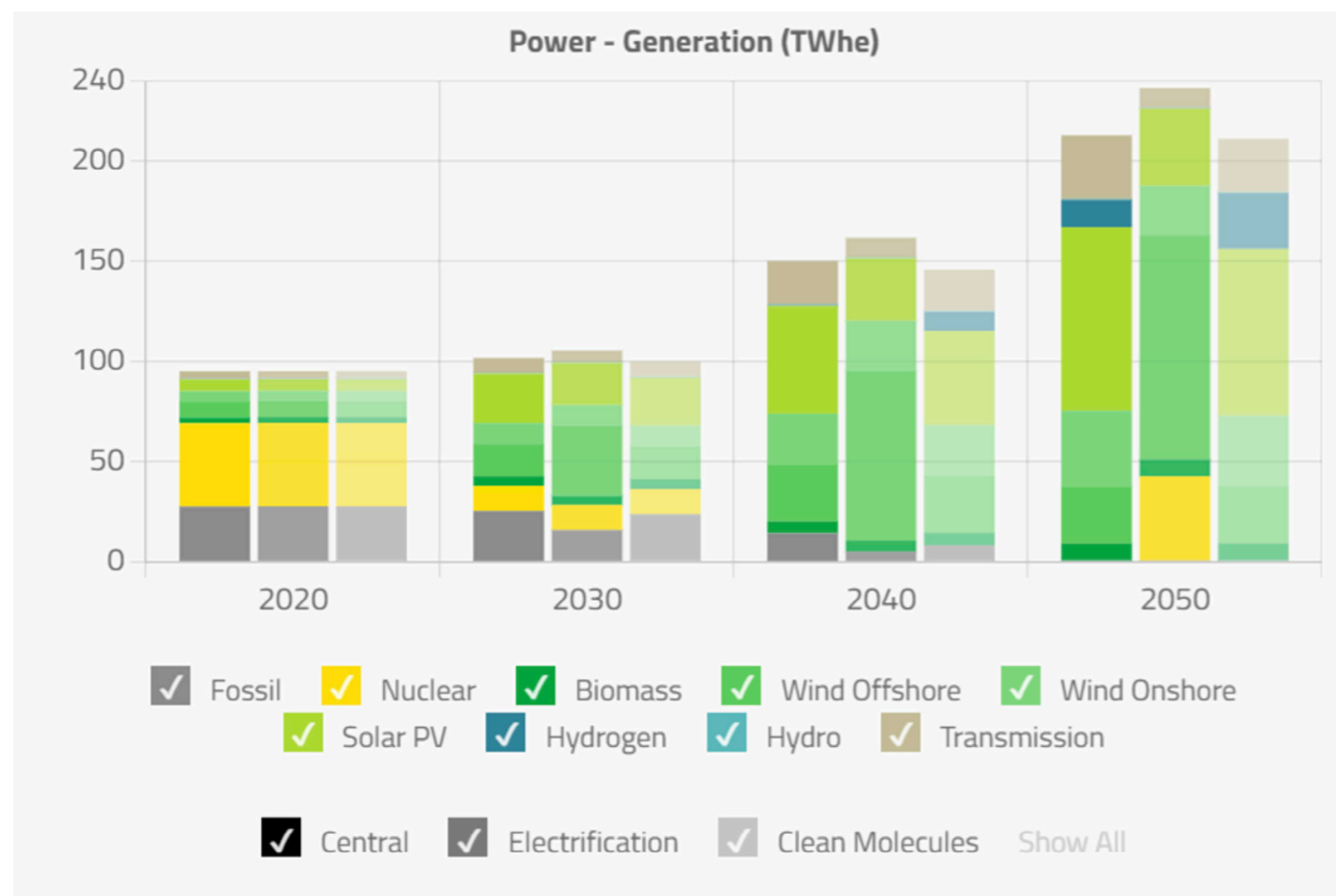

Figure 19. Electricity generation in Central, Electrification and Clean Molecules Scenarios.

Common to all scenarios is the central role renewables will play. By 2030, solar PV capacity needs to increase fourfold – up to +20 GW under all scenarios – to be on track to net zero 2050. In the case of onshore and offshore wind, the capacity doubles by 2030 as no regret cost-effective solution under all scenarios. Finally, flexibility becomes more relevant to facilitate the penetration of renewables. Thus, we see that battery capacity increases to almost 19 GW under the Central Scenario.

6.1.2 Electricity generation and demand profiles

In this section, we go into further detail when it comes to the electricity demand and generation profiles of typical Belgian summer and winter days.

6.1.2.1 Generation profile during a typical summer day in 2050

The generation of electricity typically follows the demand. When the electricity generation capacity in a country mainly comes from dispatchable power plants, the generation program can be planned and followed up. The electricity system, however, is changing towards the integration of large volumes of variable – mainly renewable – capacity. Weather forecasts become much more important to plan generation, and a market is created for short-term storage such as batteries and flexible demand to follow generation.

To examine these effects, TIMES-BE works with 10 representative days in a year – split into 2-hourly time blocks – to capture enough temporal detail in comparison to more detailed dispatch models, while still keeping the solution time-limited and providing meaningful results. Figure 20 presents the electricity generation and battery charging and discharging profiles for a typical summer day in 2050, showing the differences in the sources of electricity for particular periods (such as 18:00 and 20:00) and the differences in maximum generation for each period under the Electrification Scenario compared to the Central and Clean Molecules Scenarios.

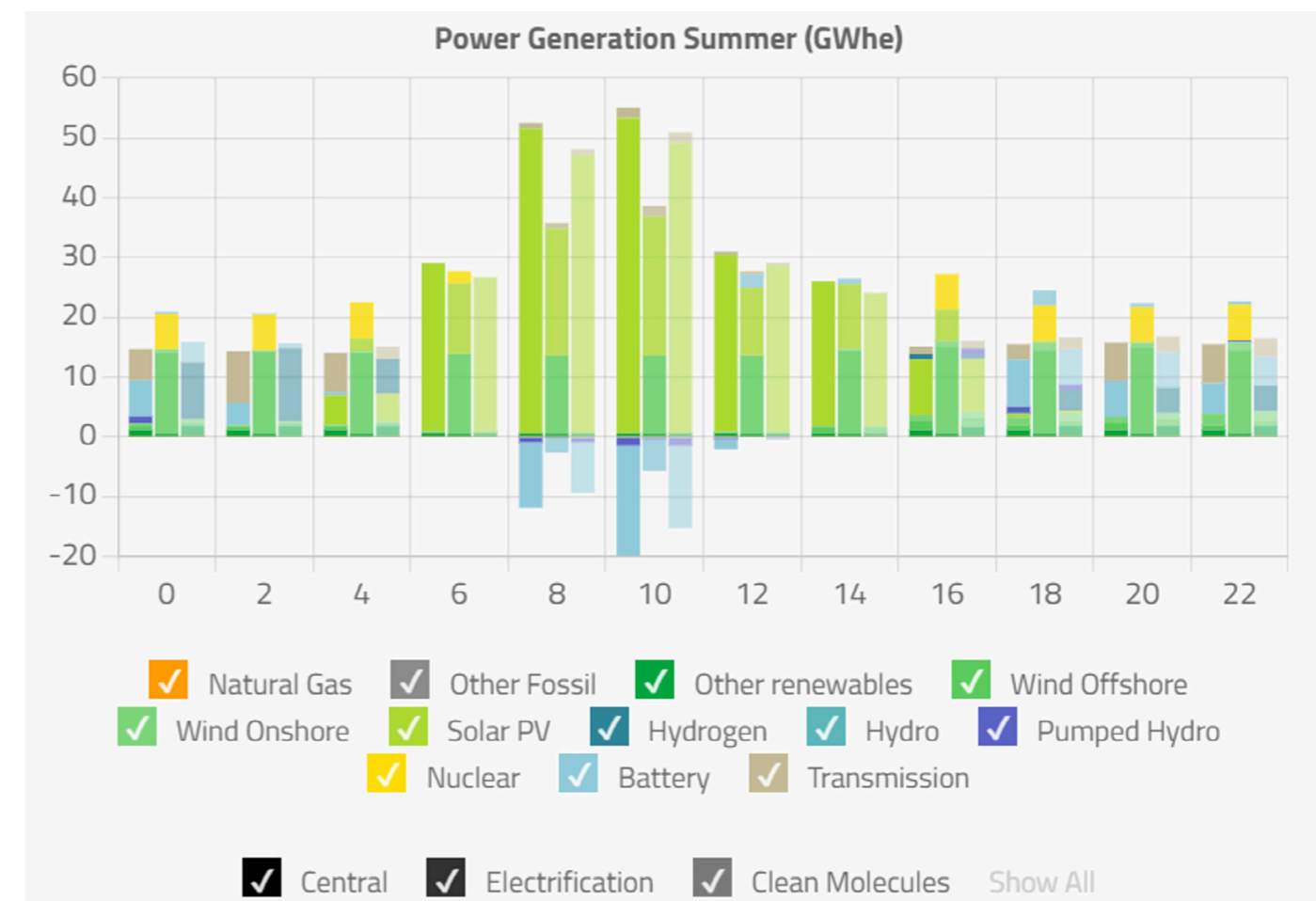

Figure 20. Power generation by source on a representative summer day in 2050 from TIMES-BE.

6.1.2.2 Demand profile during a typical summer day in 2050

To accommodate large volumes of variable renewable electricity, the electricity system requests more flexibility. Hence, the electricity demand, in combination with storage, needs to follow generation profiles. In the residential, commercial and agriculture sectors, the production of hot water (coupled with hot water storage) with heat pumps and electric boilers happens as much as possible at noon during the solar PV peak. The highest demand peak in these sectors can be seen at noon, while the current typical evening peak for cooking etc. is still visible but smaller than today. The electrification of the transport sector creates another opportunity to create flexibility in electricity demand. A more or less baseload demand of 2 GW can be noticed for freight transport and fast charging. Smart charging at home, or work, creates an electricity demand of almost 8 GW (depending on the scenario) at noon which makes it possible to optimize the injection of electricity from the solar PV peak.

Important to note is that smart charging will be crucial to reach a net zero 2050. To reach that target, at least 1.1 million smart charging stations (on average 7.5 kW peak each¹¹⁸) need to be installed. Capacity of chargers will be selected based on applications, grid characteristics and user preferences – from single-phase AC (3kW) to fast DC (50kW)¹¹⁹. Nevertheless, TIMES-BE does not completely capture user preferences and behaviour. Thus, fast chargers (+50kW) should be expected, albeit to a limited extent as is the case of the ACEA study¹¹⁶ (European Automobile Manufacturers' Association).

For the energy-intensive industry, the typical demand profile is rather flat (baseload). However, by 2050, we notice a higher demand peak at noon. This is related to investments in hydrogen electrolyzers and in the iron and steel and chemical sectors. A total capacity of up to 13.2 GW of electrolyzers makes use of the PV peak and produces 17 TWh of hydrogen in 2050 for industrial uses. An alternative to making use of the PV peak is to allow the model to make use of additional flexibility sources such as an industrial demand response.

Having access to an additional 16 GW of offshore wind and the possibility to install nuclear energy into the electricity mix – as is done under the Electrification Scenario – avoids the need for hydrogen-based power production.

118 Chargers from 4kW up to 22kW, specially for passenger cars. For freight transport capacities might be higher. In line with European EV Charging Infrastructure Masterplan, ACEA, 2022. <https://www.acea.auto/files/Research-Whitepaper-A-European-EV-Charging-Infrastructure-Masterplan.pdf>
 119 Infrastructure for charging electric vehicles: more charging stations but uneven deployment makes travel across the EU complicated, European Court of Auditors, 2021. https://www.eca.europa.eu/Lists/ECADocuments/SR21_05/SR_Electrical_charging_infrastructure_EN.pdf

As such, we see that both under the Central and the Clean Molecules Scenarios, hydrogen power plants are installed to generate electricity in extended periods with low wind and solar output. Under the Electrification Scenario, PV capacity is reduced to almost half of the capacity available under the Central Scenario, which leads to lower summer peaks at noon. As a consequence, smart charging of electric vehicles is more spread throughout the day. Due to the daily wind availability profile and the dispatchability of future nuclear plants in the Electrification Scenario, electrolyzers operate in several periods in the course of the day and are not mostly concentrated at noon. The combined peak demand over all end-use sectors amounts to 32 GW. The Clean Molecules Scenario looks more like the Central Scenario, with a difference in the total electricity demand and power peak demand of centralised electrolyzers (3.8 GW). Here, we see that cheap hydrogen import, as expected, leads to lower Belgian production, although local production is not completely replaced by import, as the electrolyzers operate in periods with very low electricity prices.

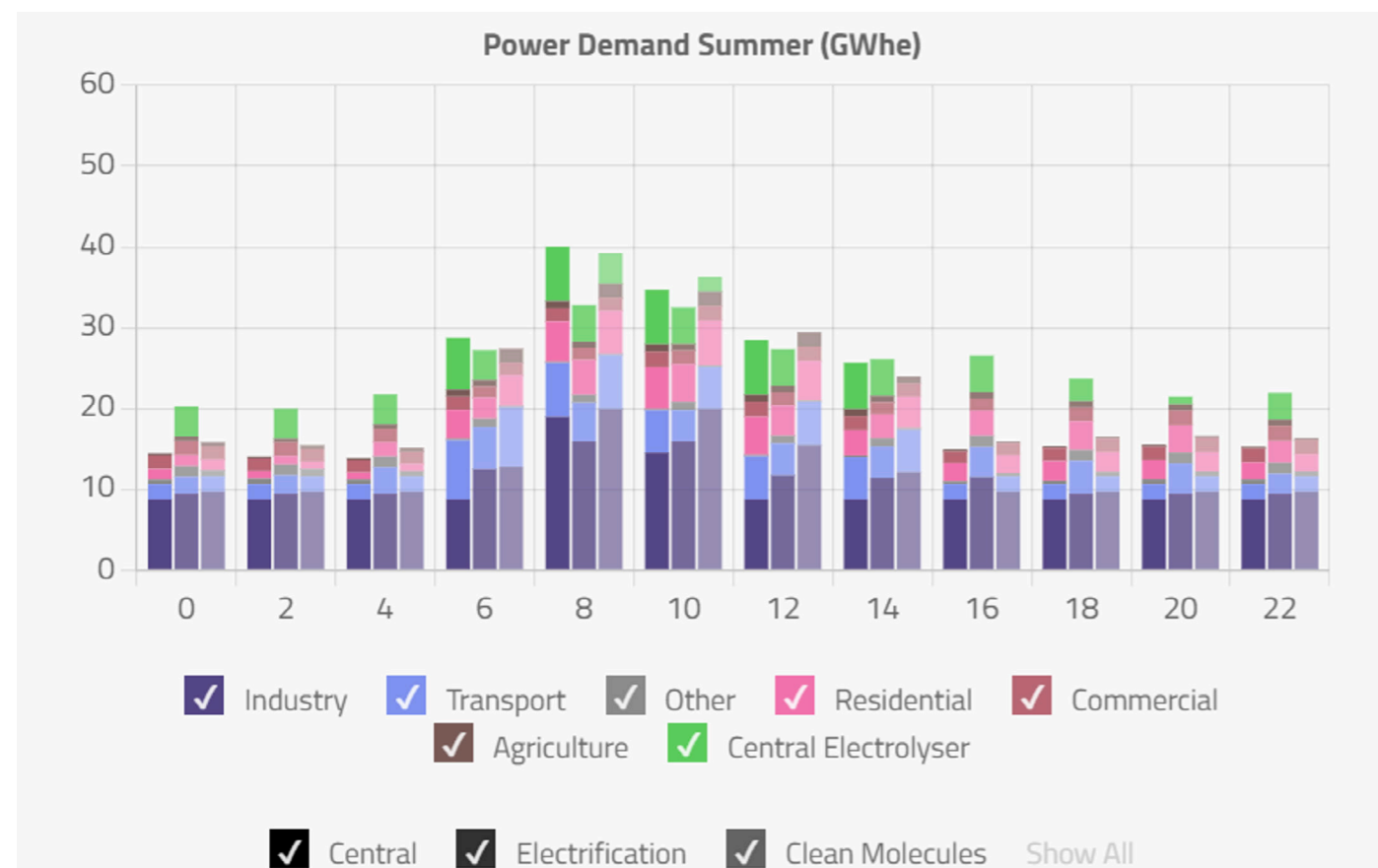

Figure 21. Demand by sector on a representative summer day in 2050 from TIMES-BE.

6.1.2.3 Generation profile during a typical winter day in 2050

Besides the differences within one particular day, it is fundamental to understand how demand behaves in other seasons and, in particular, how the more flexible technologies and demands react to price signals and electricity availability during the winter. Figure 22 shows the generation profile in the main three scenarios during a typical winter day. In this case, under the Central Scenario, the very high solar PV peak production seen at noon during the summer is not present and amounts to 11.5 GW. Moreover, battery capacity needs are limited to 2.9 GW. On the other hand, onshore and offshore wind generation reach a peak at 5 GW at noon. Nonetheless, generation still increases towards the evening. The hydrogen plants operate at full load throughout the day (8 GW), and a limited import of 5 GW is essential during the night. Total peak generation tops at less than 30 GW, which is 25 GW less than on a typical summer day.

Under the Electrification Scenario, additional offshore wind and small modular nuclear power plants complement the limited availability of Belgian PV and wind, reducing the need for hydrogen turbines and import of electricity. On the other hand, under the Clean Molecules Scenario, the generation profile of renewables resembles that of the Central Scenario, but the higher capacity of hydrogen turbines replaces electricity imports and a small share of biomass power generation.

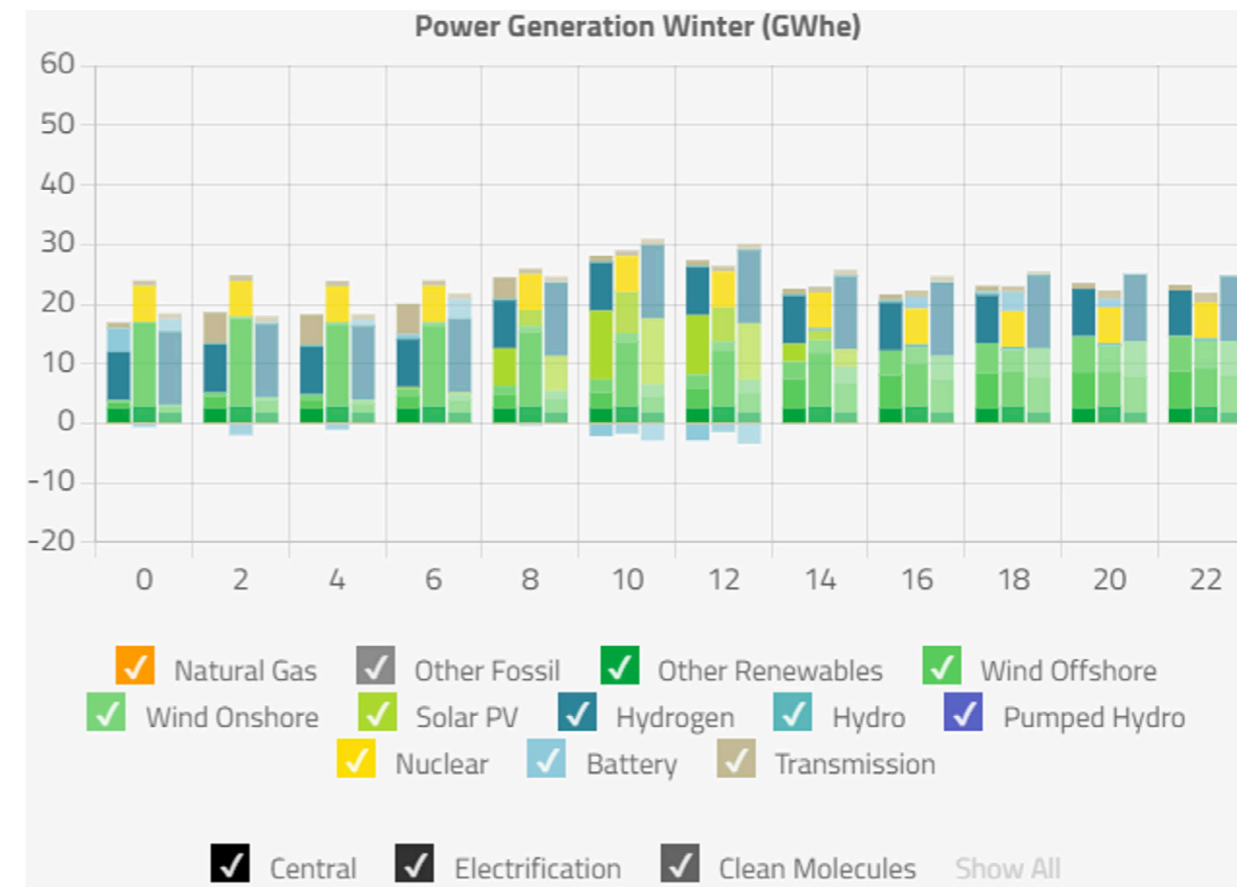

Figure 22. Power generation by source on a representative winter day in 2050 from TIMES-BE.

6.1.2.4 Demand profile during a typical winter day in 2050

The demand profile on a typical winter day in 2050 looks quite different from the demand profile on a typical summer day in 2050. Peak demand tops well below 28 GW under all scenarios. The electrolyzers providing flexible demand during the summer – are not operating during the winter. Furthermore, smart charging of electric vehicles is much more spread throughout the day. A higher heating demand during the winter increases residential and commercial demand related to heat pump operation. Nonetheless, heat pumps do have water buffers to mitigate a high peak demand in the morning or evening.

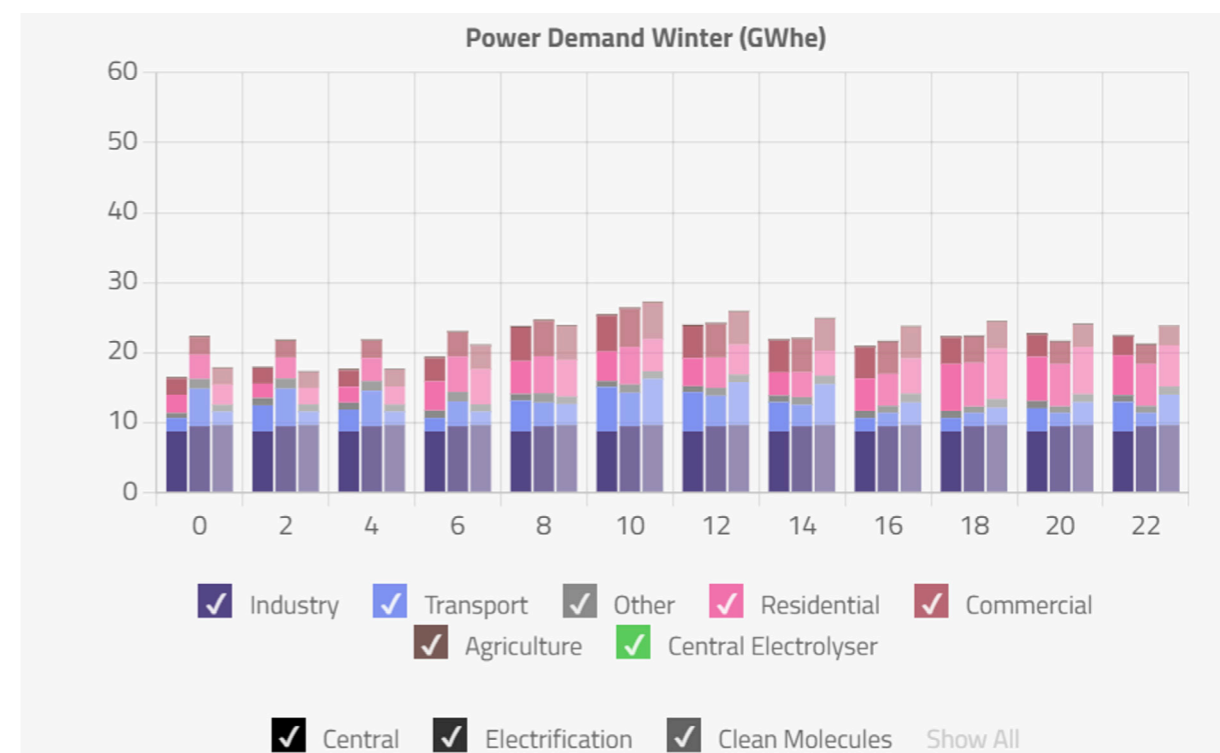

Figure 23. Demand by sector on a representative winter day in 2050 from TIMES-BE.

6.1.3 CO₂ emissions

Under all three scenarios, the power sector fully decarbonises by 2050. Under the Central and Clean Molecules Scenarios, the net zero carbon constraint only pushes the TIMES-BE model in the very last time window to invest in additional e-fuel/hydrogen-powered turbines, and to switch off the remaining natural gas CHPs and turbines. Conversely, under the Electrification Scenario, more offshore wind and SMR technology support full decarbonisation by 2050, and fossil-based technologies are replaced sooner. The power sector, thus, to a large extent, is already highly decarbonized by 2040. However, only in the last stretch running up to 2050, the last remaining 2.7-3.5 Mton of CO₂ emissions – depending on the scenario – are reduced to zero.

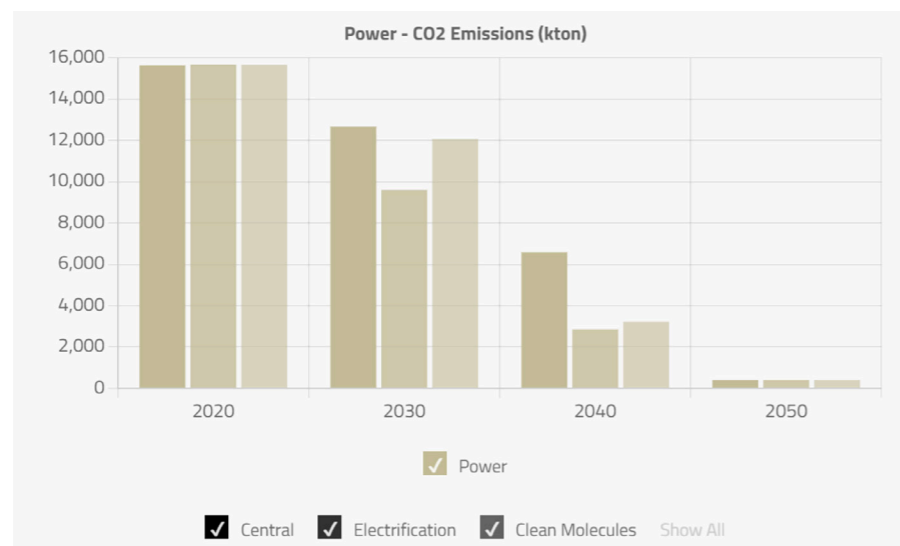

Figure 24. Power sector CO₂ emissions by scenario.

6.1.4 Annual costs

The decarbonization of the power sector will require different levels of investment cost, as well as operating costs, depending on the available technologies, resources and the price of energy carriers. Under the Central Scenario, additional annual investment and operational costs for the power sector to decarbonize increase – from 0.5 bn€ in 2030 to 4.5 bn€ in 2050. Offshore and onshore wind account for additional annual investment and operational costs of about 0.6 bn€ each, summing up to a total of 1.2 bn€, while PV accounts for 2.4 bn€ in 2050.

Under the Electrification Scenario, the integration of additional offshore wind and 6 GW of SMRs in the power sector increases the annual investment and operational costs to 5.3 bn€ in 2050 – the highest value in the three main scenarios. Under this scenario, investments in PV and onshore wind are strongly impacted. Whereas the Electrification Scenario is the most expensive when it comes to the power sector, it presents the lowest total system costs. In the case of the Clean Molecules Scenario – with access to cheap clean molecules and a limitation on carbon storage of 5 Mton/year – additional annual investment and operational costs for the power sector amount to 3.9 bn€ by 2050. It is important to highlight that under the Central and Clean Molecule Scenarios, there is no option to invest in SMRs and additional offshore wind, which is one of the main reasons for the difference in investment cost in the power sector.

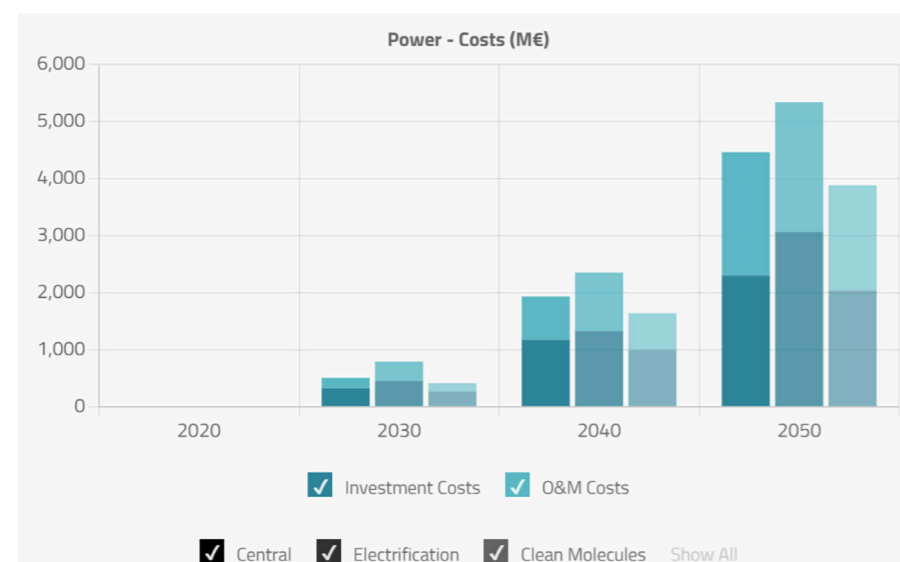

Figure 25. Power sector investment and O&M costs by scenario.

6.1.5 Electricity generation costs

The TIMES-BE model gives insights into the cost of electricity, including possible imports from other EU countries. This generation cost can be considered as a proxy for the clearing price for the day-ahead electricity market. Do note, however, that this is not the price for end consumers, as the electricity price for end consumers is subject to taxes and surcharges and transmission and distribution costs. Under all three scenarios, average generation cost peaks in 2025 due to high natural gas prices and decreases again due to investments in renewable generation capacity. Figure 26 shows the evolution of the average electricity price by scenario from 2020 up to 2050. By 2050, the Central Scenario leads to the highest price at 94 euro/MWh, mainly due to the unavailability of alternative options such as additional wind and SMRs. Conversely, under the Electrification Scenario, access to a larger capacity of offshore wind from 2030 onwards and SMR from 2045 leads to lower electricity production costs – the lowest of all three scenarios, amounting to 56 euro/MWh in 2050. When clean molecules are assumed to be cheaper, as is the case under the Clean Molecules Scenario, the average electricity production cost decreases to 84 euro/MWh in 2050, a more modest improvement compared to the Central Scenario's 94 euro/MWh.

As such, it is clear that, for Belgium, facilitating direct access to far offshore wind – as is the case under the Electrification Scenario – drastically lowers electricity and system costs from 2030 onwards in comparison to the Central and Clean Molecules Scenarios. SMR can play a similar role in reducing system and electricity generation costs from the moment it becomes available. From 2040 onwards, the need for demand flexibility grows drastically, and the use of smart charging, heat pumps with buffers, battery storage and hydrogen electrolyzers gains importance. By 2050, under the Central Scenario, hydrogen or e-fuel turbines grow to a capacity of 8 GW to provide peak power, while under the Electrification Scenario, an additional 16 GW from offshore wind and 6 GW from nuclear SMRs halve investments in solar PV and onshore wind in Belgium.

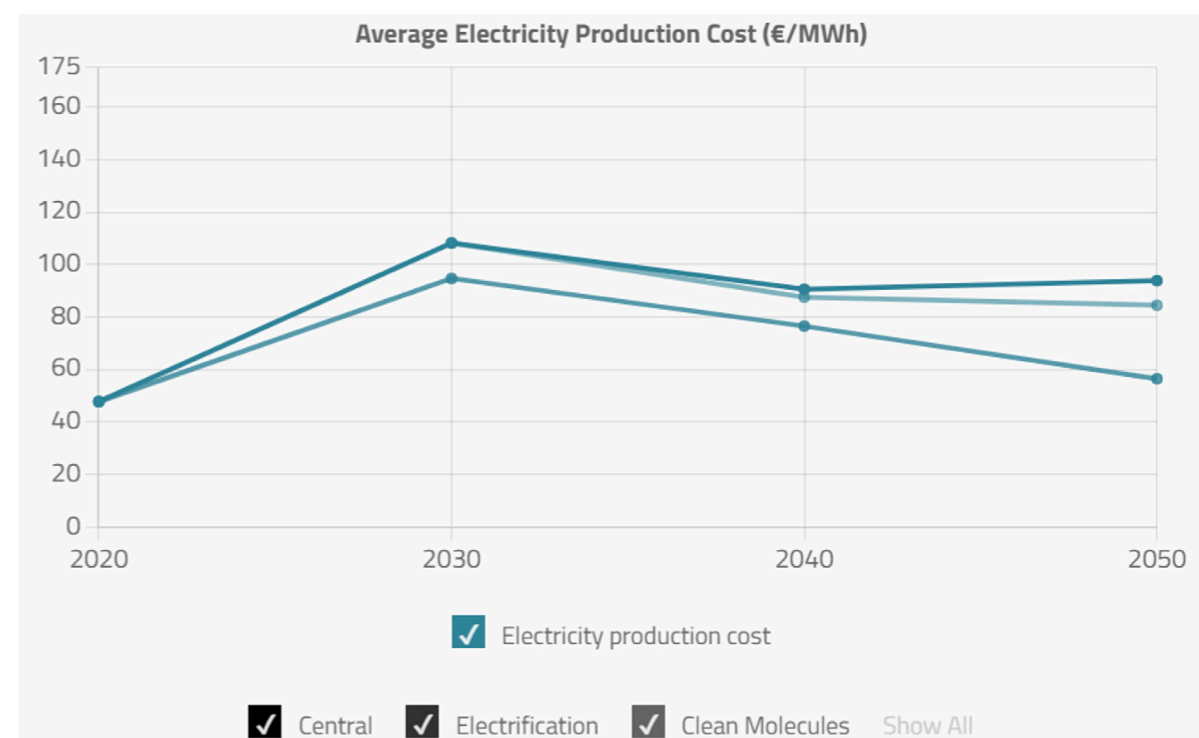

Figure 26. Annual average electricity price by scenario (day-ahead clearing price).

6.2 Industrial sector

The TIMES-BE model has been updated and extensively reviewed by industry sector federations and companies to reach a high level of detail. As such, the model consists of detailed sector representations, current production processes and technology options to reach net zero emissions by 2050 as explained in Section 4.2. For each sector, we identified different decarbonization alternatives, taking into account their particular technical limitations, and estimating cost and efficiency towards 2050. These include – but are not limited to – energy efficiency, electrification and CCUS.

6.2.1 Final energy use

In this study, it is assumed that the industrial production levels in Belgium remain constant under all three scenarios. In other words, assessing the risk of industries moving to other parts of the world – with more potential for abundant renewable energy production – is not part of this study.

Although the industrial production levels remain constant, the final energy use and mix do change drastically. Fossil fuels remain dominant until 2030, with CO₂ capture surfacing as the largest means of emission reduction. From 2040 onwards, the electrification of processes is crucial. However, compared to other sectors, electrification does not lead to large energy efficiency improvements in the industry. Heat pumps for low-temperature heating and electric mobility realise very high efficiency gains – more than a factor of three compared to the existing fossil technology. On the other hand, high-temperature electric processes in the industry – such as the electrification of furnaces – do not lead to such large efficiency gains. In certain cases, the model shows us the deployment of distributed electrolyzers; in such cases, the electricity as input to produce hydrogen is reported as electricity. In Section 6.5, we go into more detail about hydrogen use.

Under the Central Scenario, final energy use increases slightly by 2030 due to the additional heat and electricity demand of the carbon capture process. By 2040, the electrification of more processes leads to a reduction of the final energy consumption, but also to a 60% higher electricity demand compared to the base year. By 2050, the electricity demand is 2.3 times higher – mainly because of electrification of the steel production, electric furnaces in the Naphtha crackers, and a more modest increase in other sectors due to the electrification of low-temperature heat demand. The final energy consumption of clean molecules increases to 26 TWh by 2050, which is 21% of the total end-use. These clean molecules are used for high-temperature processes in the chemical industry (58%), glass and bricks (21%), steel finishing and smaller portions in the lime and cement sector. On top of the industrial use of clean molecules, 32 TWh are used in the power sector. By 2050, the total use of clean molecules in the system, is supplied mostly by imports (36 TWh) and partially by local production (23 TWh).

Although the Central Scenario has less access to electricity sources, there is still a high degree of electrification – only 7% less than under the Electrification Scenario. This is due to further electrification of the steam crackers in the chemical sector under the Electrification Scenario. The use of clean molecules in the Electrification Scenario is the same as under the Central Scenario. Under the Clean Molecules Scenario, with very cost-effective hydrogen import assumed, the degree of electrification is at the same level as in the Central Scenario in the industrial sector.

A limitation on the carbon storage potential to 5 Mton/y under the Clean Molecules Scenario leads to a much slower CO₂ reduction trajectory. Therefore, the final energy use under the Clean Molecules Scenario between 2030-2040 is lower than under the other scenarios because of lower energy demand for the carbon capture process. Electrification of processes occurs at the same pace as under the Central Scenario, but the uptake of clean molecules already starts in 2030 and increases to more than 16 TWh in 2040. By 2050, final energy use grows to 148 TWh, which is 22% more than under the Central Scenario. Due to the limit on carbon capture and storage, more processes switch to electrification and clean molecules. Even more electrification of the steam crackers in the chemical sector occurs, but the main difference is the use of more than 37 TWh of clean molecules, of which 27 TWh comes mainly from import and 10 TWh is produced in the industry. Compared to the Central Scenario, hydrogen is now also used for methanol synthesis as feedstock for the MTA and MTO processes.

As can be seen in Figure 27, until at least 2030, fossil fuels remain dominant in the industry as final energy demand, but towards 2040 a clear shift to electricity – and to a lesser extent molecules – is seen. By 2050, the electrification of industrial processes leads to double the current electricity demand under all scenarios. By mid-century, clean molecules amount to 21-25 % of the final energy demand in the industry. In addition, under the Clean Molecules Scenario, 2.5 Mton of captured CO₂ emissions are used for the production of clean methanol as feedstock for the MTA and MTO processes.

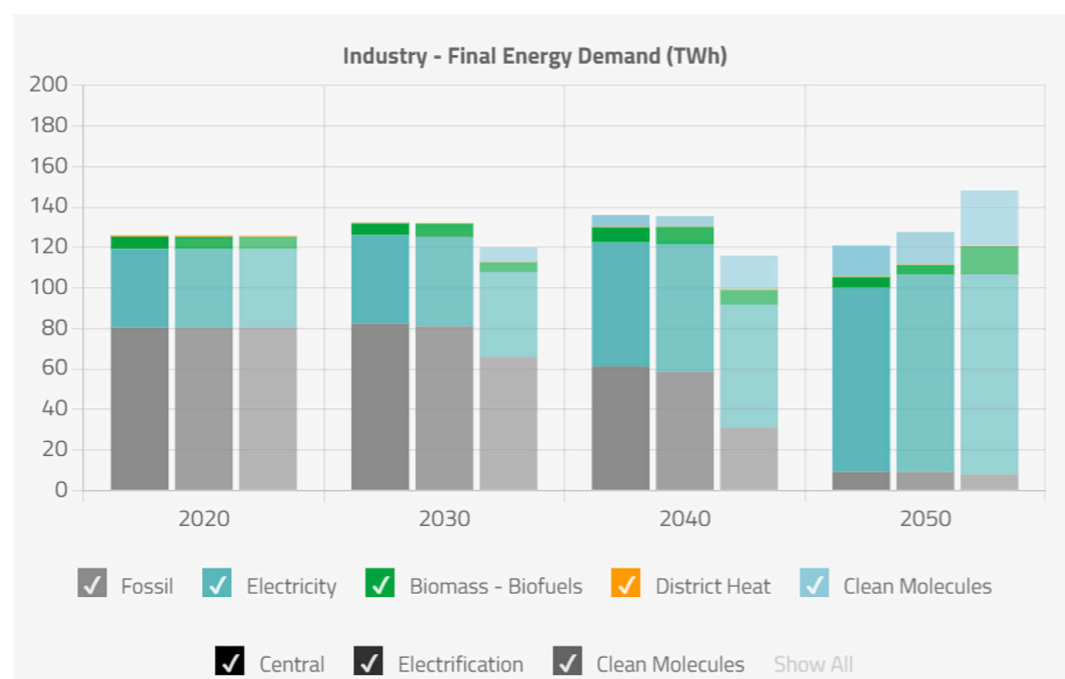

Figure 27. Industry Final Energy Demand.

6.2.2 CO₂ emissions

The emission reduction of the industrial sector follows different paths under the three scenarios (see Figure 28). In particular under the Clean Molecules Scenario, the emission reduction is slower, as the use of CCS is limited. Under the Central Scenario, CO₂ emissions decrease from almost 26 Mton today to 8.7 Mton by 2030 – a decrease mainly realised due to CCS, which removes more than 17 Mton/y of carbon emissions. CCS removes 5.2 Mton/y of carbon emissions from iron and steel, 4.7 Mton/y from high-value chemicals, 3.8 Mton/y from cement and 1.9 Mton/y from ammonia production. Other sectors with more limited CCS are glass, bricks and ethylene oxide production, where CCS removes a total of 1.7 Mton/y. CCS increases to 18.5 Mton/y by 2040, and then it also occurs in the lime sector.

The net zero constraint in 2050 cannot be solely reached with these large volumes of CCS. Thus, the captured and stored volume decreases to 7.4 Mton, whereas CCS is still needed for the high-value chemicals and typical non-avoidable process emissions in cement and lime production. As explained in paragraph 6.2.1 Final energy use, electrification and the use of clean molecules realise further CO₂ reduction. The remaining industrial emissions account for 1.4 Mton/y by 2050.

Under the Electrification Scenario, although 2 Mton less of CCS is used because of the higher electrification rate, in general, the impact of this scenario on the CO₂ reduction trajectory is small compared to the Central Scenario. Conversely, under the Clean Molecules Scenario, the limited access to carbon storage – capped to 5 Mton/y from 2030 onwards – puts a constraint on the CO₂ emission trajectory for the industry. Emissions in 2030 are 18.2 Mton – more than double the amount of the Central Scenario emissions. In 2030, only 2.7 Mton/y of industrial emissions are captured and stored – namely the process emissions in the cement sector. The other 2.3 Mton/y of CCS occurs in the transformation sector (refineries). By 2050, a total of 7.5 Mton/y are captured, of which 5.4 Mton/y in the industry, mainly in cement and lime production. Since only 5 Mton/y can be stored, the remaining 2.5 Mton/y are used for methanol synthesis.

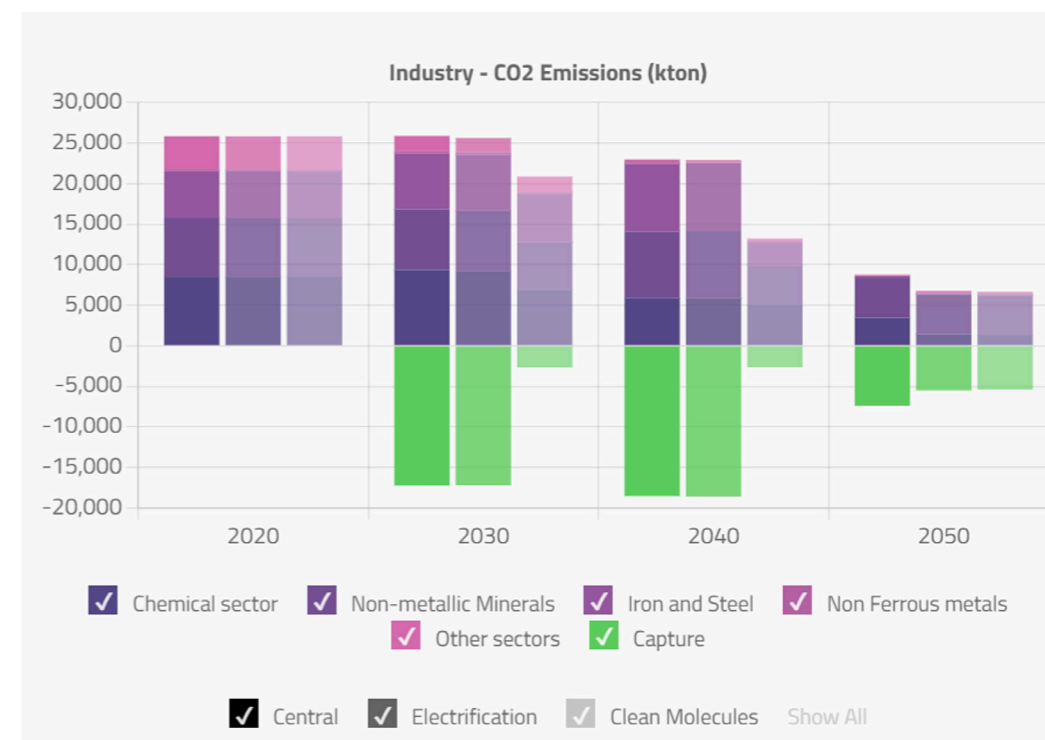

Figure 28. Total industry CO₂ emissions by scenario from 2020 to 2050.

The use of CCUS for industrial decarbonization is deemed decisive, although subject to several sensitivities such as technology maturity, investment cost and – probably more importantly – access to storage facilities. By 2030, under the Central and Electrification Scenarios, CCUS avoids the release of 17 Mton of CO₂ emissions into the atmosphere. In 2040, under the Clean Molecules Scenario, limited access to commercial carbon storage to 5 Mton leads to 10 Mton higher industry emissions compared to the Central Scenario. By 2050, under the Central Scenario, CCUS is limited to 7.4 Mton and applied in cement, lime and high-value chemicals. Under the Electrification and Clean Molecules Scenarios, on the other hand, CCUS stabilizes at 5.5 Mton (CCS is 5 Mton and CCU 0.5Mton).

6.2.3 Annual costs

Due to the optimisation and perfect foresight principle of TIMES-BE, the model starts investments in low-carbon technologies from 2030 onwards. The sum of the undiscounted, annual depreciation of investments and operational costs for the industry – needed to go from a scenario with a constant carbon tax of 50 €/ton to a net zero 2050 future – under the Central Scenario amounts to + 0.87 Bn€, +1.08 Bn€ and + 2.34 Bn€ in 2030, 2040 and 2050 respectively.

Under the alternative scenarios, and compared to the Central Scenario, there are differences due to the decarbonization alternatives used. Under the Electrification Scenario, the electrification of processes occurs at the same pace, but the annualised investment and operational costs for the industry are 0.24 Bn€ lower by 2050. While under the Clean Molecules Scenario, the limited access to carbon storage (5 Mton/y maximum) from 2030 onwards puts a constraint on the CO₂ emission reduction trajectory for the industry. Therefore, CO₂ reductions are achieved at a slower pace, leading to lower costs in 2030 and 2040 compared to the Central Scenario. However, in 2050, the lower costs of clean molecules do not outweigh the limited access to carbon storage. Achieving net zero under this scenario leads to a higher annual cost for the industry of 2.41 Bn€.

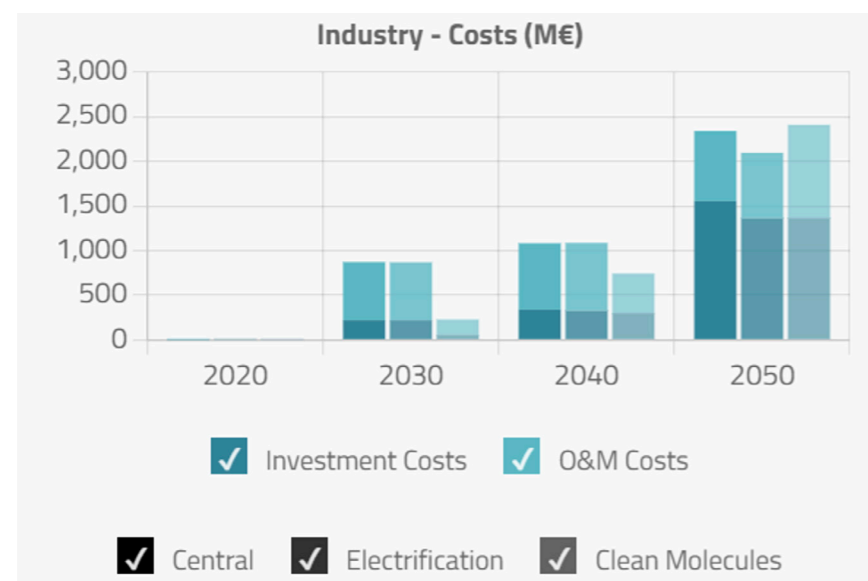

Figure 29. Investment and O&M cost by scenario.

6.3 Residential and commercial sectors

Today, the residential and commercial sectors are considered non-ETS sectors – meaning they are not subject to the European carbon price – with a joint final energy demand of 34%. Since these sectors together are responsible for almost 20% of today's Belgian CO₂ emissions, a huge effort is required to reach carbon-neutrality here.

The European Commission proposed to introduce carbon pricing for buildings by regulating fuel suppliers as of 2026. As such, we imposed an increasing carbon price to all sectors to create a level playing field and let the TIMES-BE model search for the most cost-effective trajectory to net zero by 2050. To achieve this target, the sectors have decarbonization options where technically possible, such as energy efficiency improvements, fuel substitution, electrification and the use of synthetic molecules.

6.3.1 Final energy use

As a general conclusion, we can state that the impact of the different scenarios is negligible in the residential and commercial sectors. Under all three scenarios, the key to decarbonise these sectors is renovation, increased insulation and heat pumps (with a special role reserved for district heating fed by waste heat), deep geothermal energy or centralized heat pumps in suitable regions/districts with dense buildings patrimony and high demand of heat. Although the use of clean molecules was modelled too, this was not selected as a cost-effective solution by the model.

Today, natural gas and fuel oil represent more than 65% of the final energy demand in these sectors, mostly used for heating and hot water purposes. Electricity represents 34% of the final energy demand. A cost-effective trajectory towards a net zero 2050 shows rapid investments in building insulation and a complete phaseout of fuel oil by 2030. By 2050, renovation leads to energy savings of 0.6 TWh in existing buildings. This is complemented by the deployment of heat pumps. In fact, electric heat pumps and – to a smaller extent – district heating and biomass replace the fuel oil boilers. Natural gas use decreases by more than 20% by 2030. By 2050, we notice a complete shift from natural gas to electric heat pumps, and a limited amount of district heating as well.

In this way, the final energy demand in these sectors decreases from 122 TWh today to 70 TWh by 2050, which is a 43% efficiency improvement. Electricity demand amounts to 62 TWh or 89% of the final energy use. Noteworthy is that this is only possible due to the use of highly efficient heat pumps, which are easily three times more efficient than a new gas boiler. Heat pumps are modelled with a heat buffer tank, so they can provide flexibility on a daily basis – for instance by operating during solar PV peak production. As colder outside temperatures have a negative impact on the efficiency of a typical air to –air or air to water heat pump, the seasonal efficiency of the ambient air heat pumps is also taken into account.

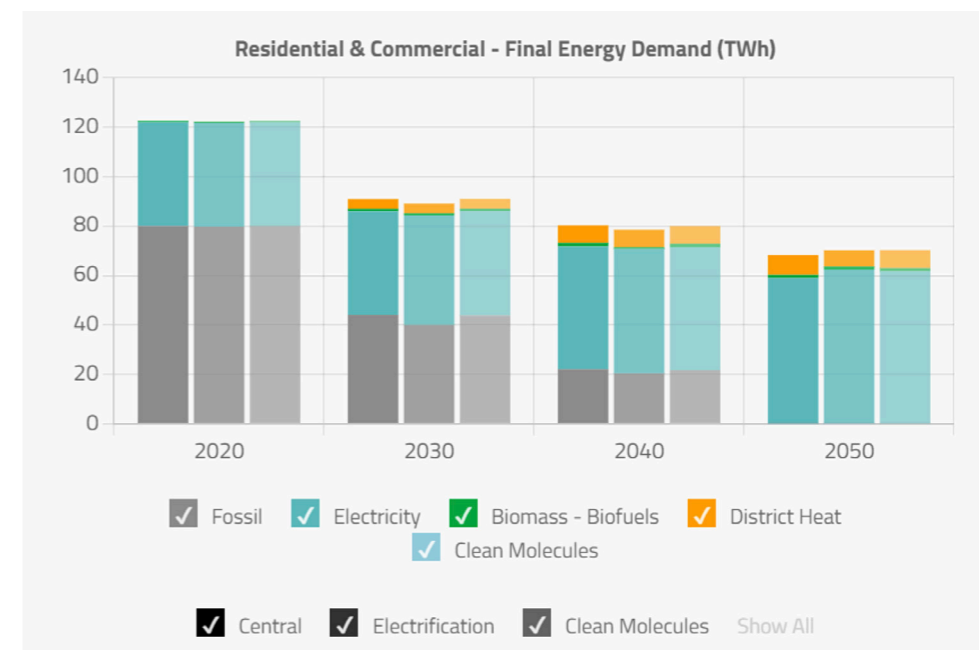

Figure 30. Final Energy Demand of residential and commercial sectors from TIMES-BE.

6.3.2 CO₂ emissions

The impact of the different scenarios on the decarbonisation choices made is negligible in the residential and commercial sectors. Under all scenarios, CO₂ emissions are almost halved by 2030. Energy efficiency measures and fast electrification of the final energy use lead to fast CO₂ emissions reductions and a fully decarbonised sector by 2050. By 2030, renovation, insulation and fuel oil phaseout realise a 50% CO₂ reduction. Energy efficiency measures and electrification lead to the status quo in electricity demand, where heat pumps are installed in 1.5 million residential homes and commercial buildings. Later, by 2050, district heating (8TWh) fulfils the demand of at least 800¹²⁰, while at the same time heat pumps with water buffers and electric water heaters provide flexibility to a highly renewable electricity system.

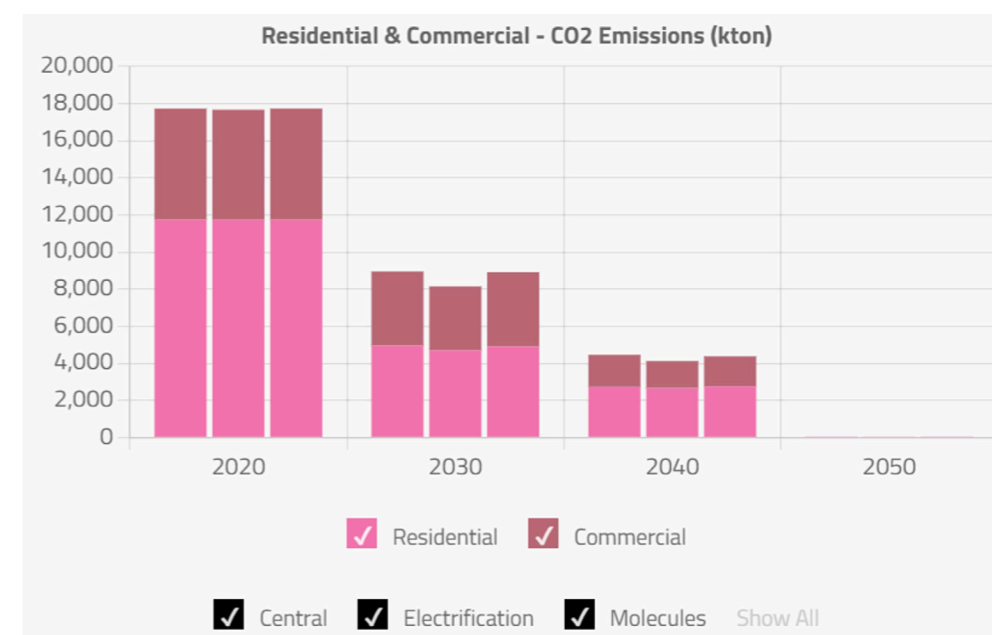

Figure 31. CO₂ emissions for residential and commercial sectors.

120 Assumption: average heated surface 100 m², heating demand <100 kWh/m².

6.3.3 Annual costs

The high gas/fuel prices and increasing carbon tax boost energy efficiency measures and electrification of the final energy demand. Although the three scenarios showed comparable results regarding final energy use and CO₂ emissions, the annual costs to go from a scenario without climate ambition (run with a constant 50 €/ton carbon tax) to a net zero 2050 future are different.

- Central Scenario: annual investment and operation costs amount to 0.7 Bn€ by 2030 and 2.2 Bn€ by 2050.
- Electrification Scenario: annual investment and operational costs are the same as under the Central Scenario for 2030-2040, but amount to 1.6 bn€ by 2050. These lower costs can be explained by a lower investment need in home battery systems due to the lower solar PV investments (-0.4 bn€ compared to the Central Scenario) and a partial switch from heat pump systems for water heating to cheaper resistance heaters due to the lower electricity production costs (and wholesale prices) under this scenario.
- Clean Molecules Scenario: lower electricity production costs (and wholesale prices) under this scenario lead to lower costs in 2050, and this due to a partial switch from heat pump systems for water heating to cheaper resistance heaters compared to the Central Scenario.

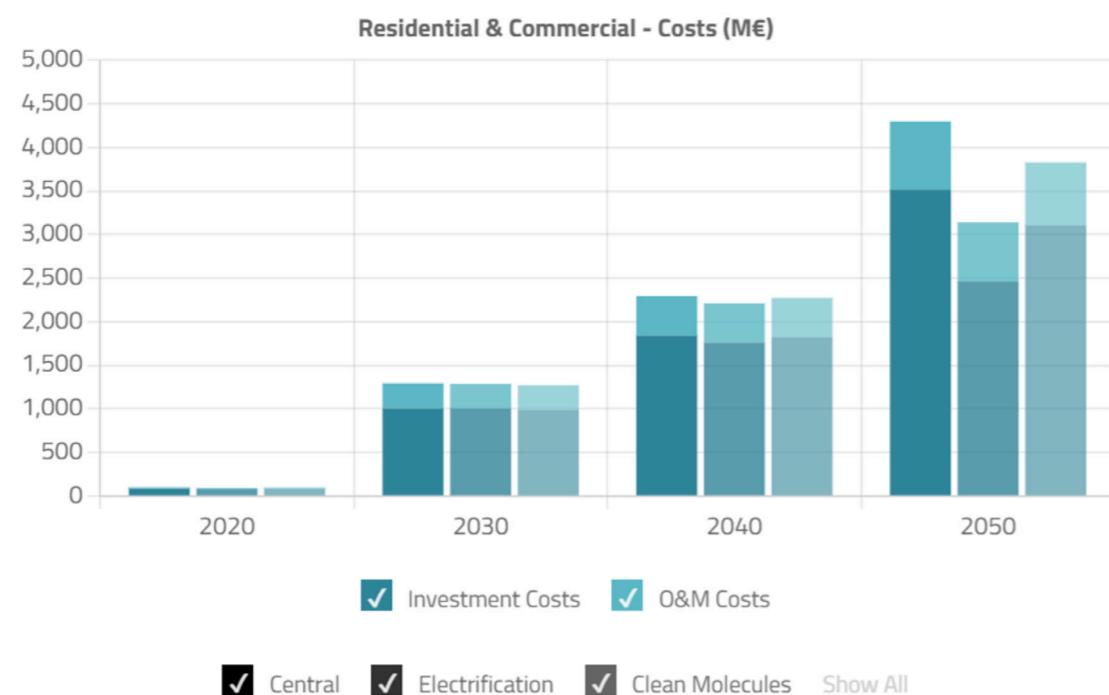

Figure 32. Residential and commercial sectors investment and O&M costs by scenario.

6.4 Transport sector

Transport is the only sector in which energy use and CO₂ emissions are still growing year by year. Road transport (person and freight) is responsible for 96% of the final energy use. Rail and a small part of domestic shipping and aviation are taking up the remaining 4% share. Current final energy use amounts to 27% and CO₂ emissions to 28% of Belgium's total. Fossil fuels dominate 95% of the final energy demand, with a small share of blended biofuels and electricity. TIMES-BE includes the possibility to use fuel substitution, electrification (plug-in hybrid and full electric) and the use of synthetic fuels to decarbonize the sector by 2050. The energy demand of international aviation and shipping are taken into account in this analysis; their emissions, however, are not subject to CO₂ prices, since international emissions are not accounted for in Belgium's national inventory of GHG emissions¹²¹.

6.4.1 Final energy use

Electrification of road transport is crucial to decarbonising this sector. By 2030, under the three scenarios, the model shows an uptake of 2 million electric passenger cars. By contrast, freight and heavy transport are still expected to rely on diesel fuel in 2030, 2040 and possibly even 2045. It is important to note, however, that TIMES-BE only considers underlying techno-economic costs and does not account for external factors such as taxes, subsidies, incentives, and so on. Currently, fossil fuels for heavy-duty transport are subject to high taxes, which could expedite the electrification of heavy-duty vehicles in real life - potentially sooner than the model results indicate.

Under all three scenarios, full electrification is selected as a cost-effective solution by 2050 (30 TWh). In 2040, the speed of electrification is higher under the Electrification Scenario due to faster uptake of electric trucks, and also slightly higher under the Clean Molecules Scenario due to access to cheaper and low carbon electricity. Electrification leads to a huge energy efficiency improvement. The final energy use decreases from almost 100 TWh in 2020 to 34 TWh in 2050 – that is a 76% reduction. The use of clean molecules for road transport is not cost-effective to reach net zero. By 2050, at least 1,1 million smart charging stations – with an average 7.5 kW peak – are needed to provide demand flexibility.

Today, rail transport in Belgium is almost completely electrified, and an increase in the rail transport (person and freight) is reflected in a higher electricity demand (total of 2 TWh in 2050). Rail uses only 7% of the electricity demand compared to the road transport. The very small energy share of inland shipping and aviation switches to biofuels and hydrogen respectively. We can expect a much larger need for clean molecules to bring international aviation and international shipping on track to reach net zero.

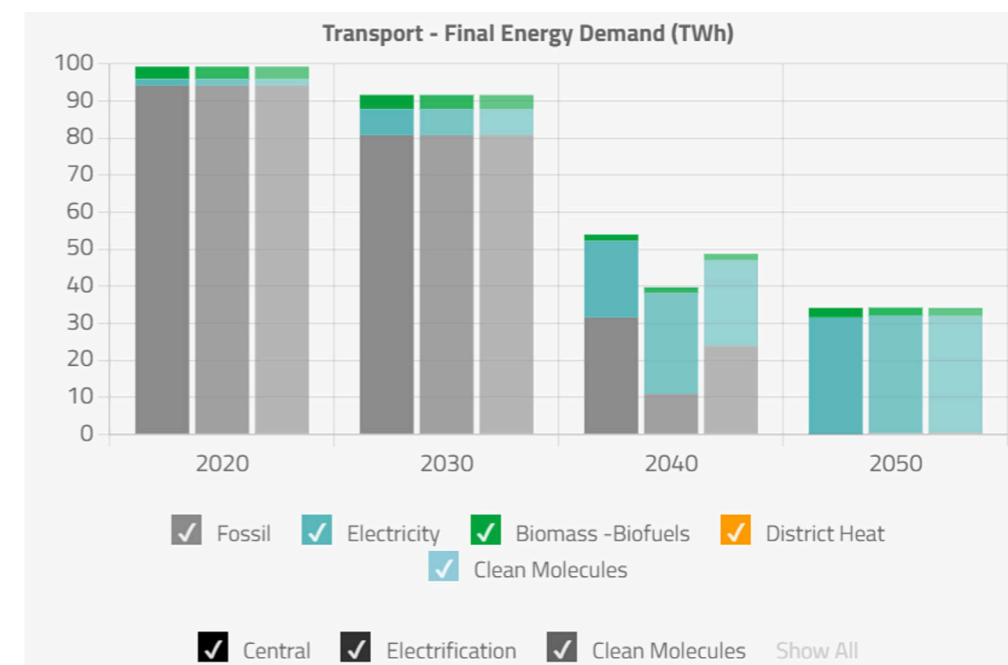

Figure 33. Final Energy Demand of transport sector.

6.4.2 CO₂ emissions

The transport sector fully decarbonises by 2050, but the speed of CO₂ reduction differs under the three scenarios. The faster electrification of road transport in 2040 under the Electrification and the Clean Molecules Scenarios leads to lower CO₂ emissions compared to the Central Scenario - especially under the Electrification Scenario, as can be seen in Figure 34. Investing in more than 2 million electric passenger cars by 2030 would be cost-effective, and puts us on track to reach net zero in 2050. Note, however, that the transition in this sector takes place after 2030, as a big part of existing vehicles reach the end of their lifespan between now and then, and are thereafter replaced by EVs.

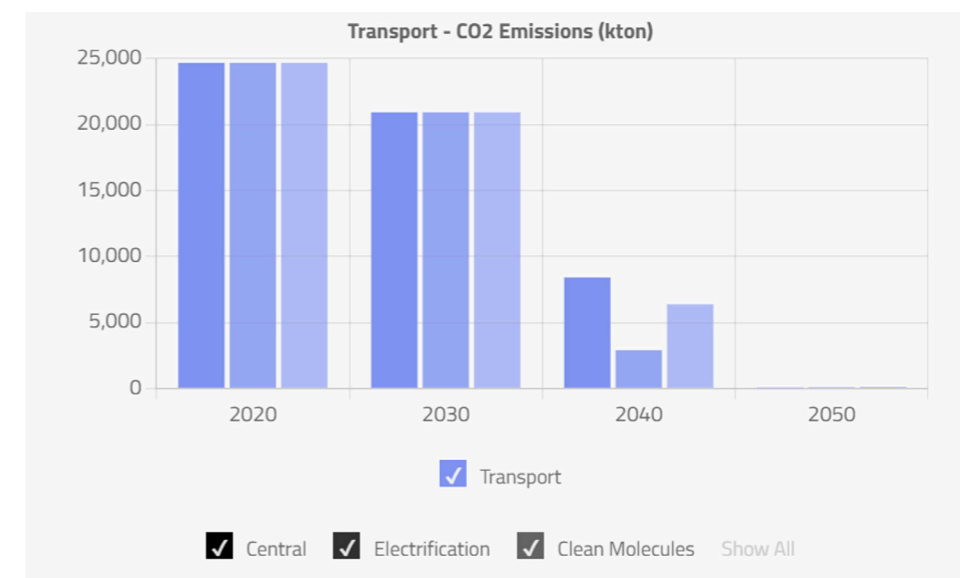

Figure 34. CO₂ emissions from the transport sector.

6.4.3 Annual costs

Electrification of the road transport sector will come at a cost. The transition from a scenario without stringent climate ambition (run at a CO₂ tax of 50 €/ton) to a net zero 2050 will add an annual investment and operational cost of 9.5 bn€ under the Central Scenario. We can conclude from this that electrification of the road transport sector (mainly trucks) will only take place at CO₂ prices higher than 50 €/ton. The largest share of the cost will go to the purchase of electric vehicles and trucks at a higher cost than the alternatives with a combustion engine. Besides these costs, we also allocated costs for strengthening the distribution grid and charging infrastructure for the transport sector.

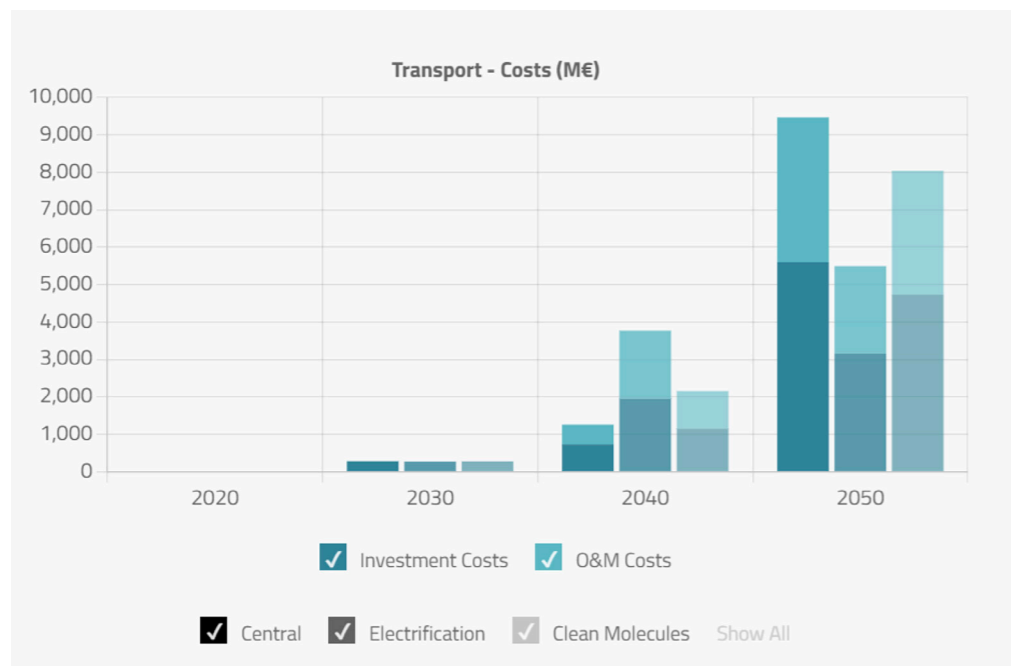

Figure 35. Transport sector investment and O&M costs by scenario.

6.5 Hydrogen

Although hydrogen is not a sector as such, we nevertheless decided to zoom in on its flows through the TIMES-BE model. Hydrogen is not an energy source in and of itself – rather, it is an energy carrier, as it is produced from e.g., natural gas. In the TIMES-BE model, hydrogen and derivatives can enter the Belgian energy system through the following routes:

- Import of pure hydrogen through pipelines.
- Import of liquid hydrogen, e-methane, methanol or ammonia by ship.
- Local hydrogen production (natural gas steam reforming, biomass gasification, electrolyzers and pyrolysis).

Hydrogen use options are modelled in most end-use sectors, but the model results show that it is only selected for the power sector and some industries.

6.5.1 Hydrogen supply and demand

6.5.1.1 Hydrogen supply

Until 2030, hydrogen production in Belgium is dedicated to ammonia production through an existing Steam Methane Reforming process. Then, from 2030 onwards, steam reformers operate with Carbon Capture and Storage – so-called blue hydrogen. Later, the production of green hydrogen in Belgium starts growing after 2035 under the three scenarios. The installed electrolyser capacity takes advantage of periods of high renewable electricity production and lower electricity prices – in particular during the summer, when solar PV production is high.

Under the Central scenario, electrolyser capacity increases from 8.2 GW in 2040 to 13.2 GW by 2050. In 2050, 5 GW of this capacity is installed centrally in the energy system to produce 12.5 TWh of hydrogen. The remaining 8.2 GW are installed in the industry (steel and chemical sector). The electricity use of these electrolyzers was reported in the final energy demand in the industry sector (Section 6.2.1). The hydrogen produced is not visible in the final energy demand but amounts to 10.6 TWh. Import of hydrogen increases slowly from 2040 onwards, and reaches a total volume of 36 TWh in 2050.

Under the Electrification Scenario, electrolyser capacity amounts to 8.2 GW by 2050, which is 5 GW lower than under the Central scenario. However, even though electrolyser capacity is lower in 2050, hydrogen production is higher (28 TWh).

This shows that electrolyzers will operate annually at 3400 full load hours and this due to having access to a more constant electricity supply at a lower generation cost. The imported hydrogen also decreases to 5 TWh, as less hydrogen is required for the production of electricity during critical moments (evening peaks and during the winter).

Under the Clean Molecules Scenario, electrolyser capacity increases to 10.4 GW by 2050 with a production of 13.7 TWh. And hydrogen imports at a lower price already start in 2030 under this scenario, with an increase to 91 TWh by 2050.

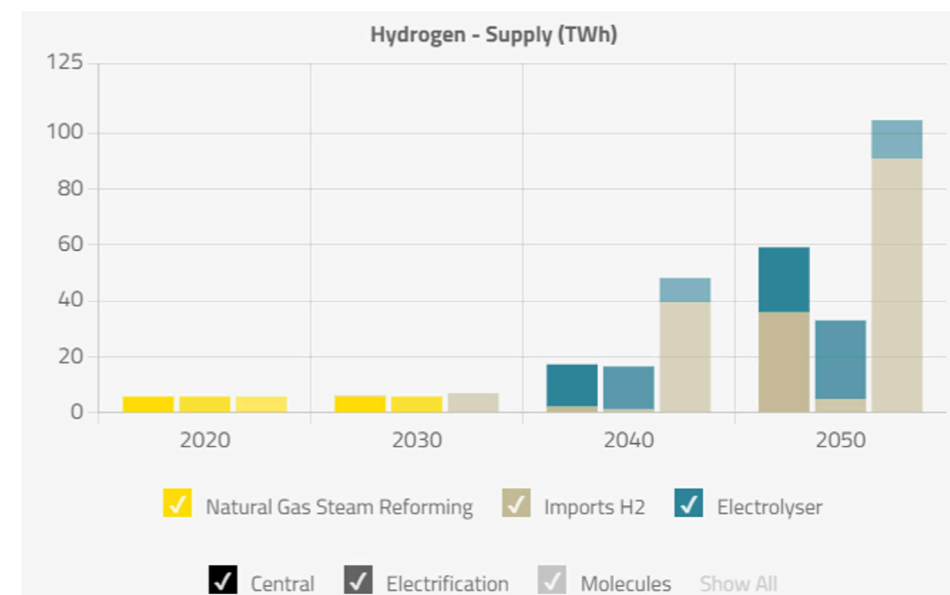

Figure 36. Hydrogen supply by source.

6.5.1.2 Hydrogen demand

In the model results, hydrogen demand can be observed in the power sector and the industry. Under the Central and Clean Molecules Scenarios, hydrogen use in the power sector increases drastically towards 2050, utilised in hydrogen peaking turbines. Under the Electrification Scenario, no investments in hydrogen peak turbines take place.

Hydrogen use in the industry takes place under all three scenarios. Clean molecules are used for high-temperature processes in the chemical industry, glass and bricks, steel finishing, and smaller amounts in the lime and cement sector. Under the Clean Molecules Scenario, on top of these mentioned uses, hydrogen is also used for methanol synthesis as feedstock for MTA and MTO processes.

It should once again be noted that, in this study, the full feedstock and international maritime and aviation sector (bunker fuels) are not included in the analysis, and are not pushed to be transformed to carbon-neutral alternatives. This may potentially lead to a much larger hydrogen/synthetic fuel demand.

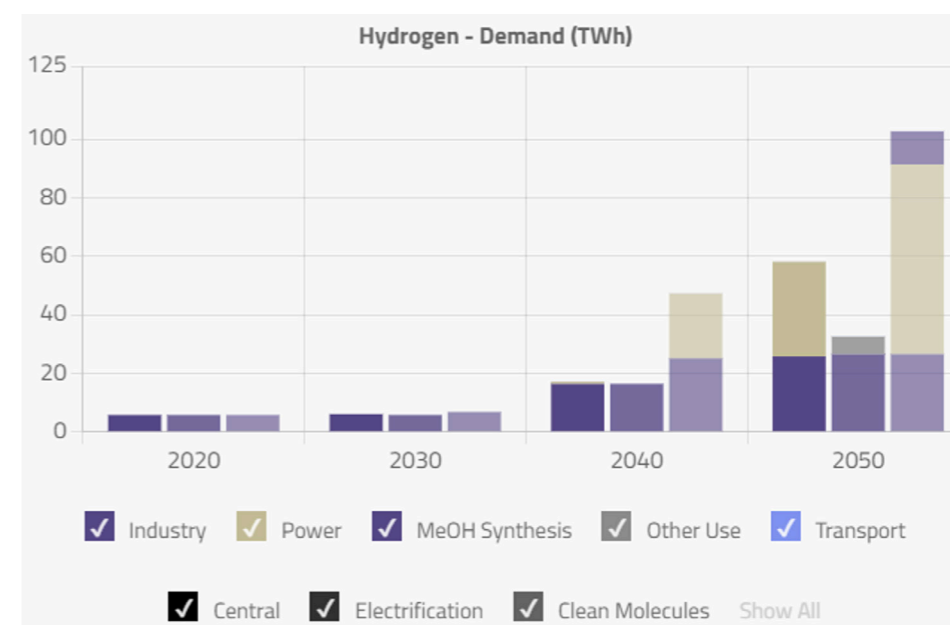

Figure 37. Hydrogen demand by final use.

7. Sensitivity cases' results

The results of the sensitivity analysis confirm the key findings of the main analysis, indicating that a rigorous selection of fundamental scenarios was implemented. Furthermore, additional insights are presented with regard to the challenges associated with achieving rapid electrification and the impact of choices and technological assumptions on costs. This section provides a detailed explanation of the selection of sensitivity cases, and covers the primary conclusions for each analysed model run. This process yields valuable insights into key areas such as offshore wind, photovoltaic efficiency, Small Modular Reactors (SMRs), industry flexibility, carbon storage limitations and carbon reduction trajectories. The sensitivity cases encompass variations of the Electrification Scenario, including those related to PV cost, industry flexibility and carbon storage limitations. Regarding offshore wind, SMRs and near-zero sensitivities, the Central Scenario serves as the reference. Table 22 provides a clear definition of the six main sensitivity cases leading to ten sensitivity model runs, along with the corresponding reference scenario and primary differences.

Sensitivity case	Reference scenario	Definition	Different model runs
Offshore wind	Central Scenario	Additional access to large offshore wind zones in the North Sea from 2030 and to a maximum of 16GW or 32GW by 2050, on top of the 8 GW in the Belgian territorial zone.	<ul style="list-style-type: none"> Direct connection to 16 GW additional offshore capacity. Unlimited access to additional offshore capacity.
PV efficiency and cost	Electrification Scenario	This case is made up of two sensitivities. In the first, PV efficiency increases from 23% to 35% (e.g., tandem cells). In the second sensitivity, PV is forced to go to 75% of its technical potential by 2040.	<ul style="list-style-type: none"> PV efficiency from 23% to 35%. Forced quicker deployment of PV.
Small Modular Reactor (SMR)	Central Scenario	Without access to additional offshore wind, SMR might play a more relevant role. However, to account for uncertainty, the impact of lower and higher investment costs is considered.	<ul style="list-style-type: none"> SMR at 4,500 €/kW SMR at 7,500 €/kW as in the Central Scenario SMR at 10,800 €/kW
Industry flexibility	Electrification Scenario	Possible investment in flexibility for some key industrial demands, where the annual production of intermediate and final products remains stable. Additional capacity comes at a cost but allows to produce more during periods of low energy prices (or costs) and less during periods of higher energy prices. The following industrial sectors/processes, which can technically provide flexibility, are included: chlorine, steel (EAF, MOE), copper, zinc and chemical sector (electrical cracking furnaces).	Selected processes can invest in additional capacity and operate at different levels each period (2 hours).
Carbon storage limitation	Electrification Scenario	There is limited access to cross-border CO ₂ storage: Belgium's access to cross-border CO ₂ storage is limited to 5 million tons per year.	Maximum CCS use of 5 MtCO ₂ .
Near-zero emissions (85% reduction)	Central Scenario	In contrast to the other cases, this sensitivity does not reach net zero carbon emissions. Here, carbon price, reaching €350/tCO ₂ in 2050, is the sole decarbonization driver. There is no net zero constraint by 2050.	No net zero constraint by 2050.

Table 22. Definition of sensitivity cases and differences with reference to main scenarios.

7.1 Impact of sensitivity cases on the energy system

The sensitivity cases had a significant impact on certain sectors, namely the power sector and carbon capture usage and storage. This can be seen in Figure 38, which illustrates the differences in electricity generation by technology between the three main scenarios and the six sensitivity cases (ten sensitivity model runs). Additionally, Figure 39 presents the installed capacity of various technologies, while Figure 40 displays the emissions by sector and the volume of captured CO₂. Overall, these figures provide valuable insights into the effects of the sensitivity cases on specific sectors.

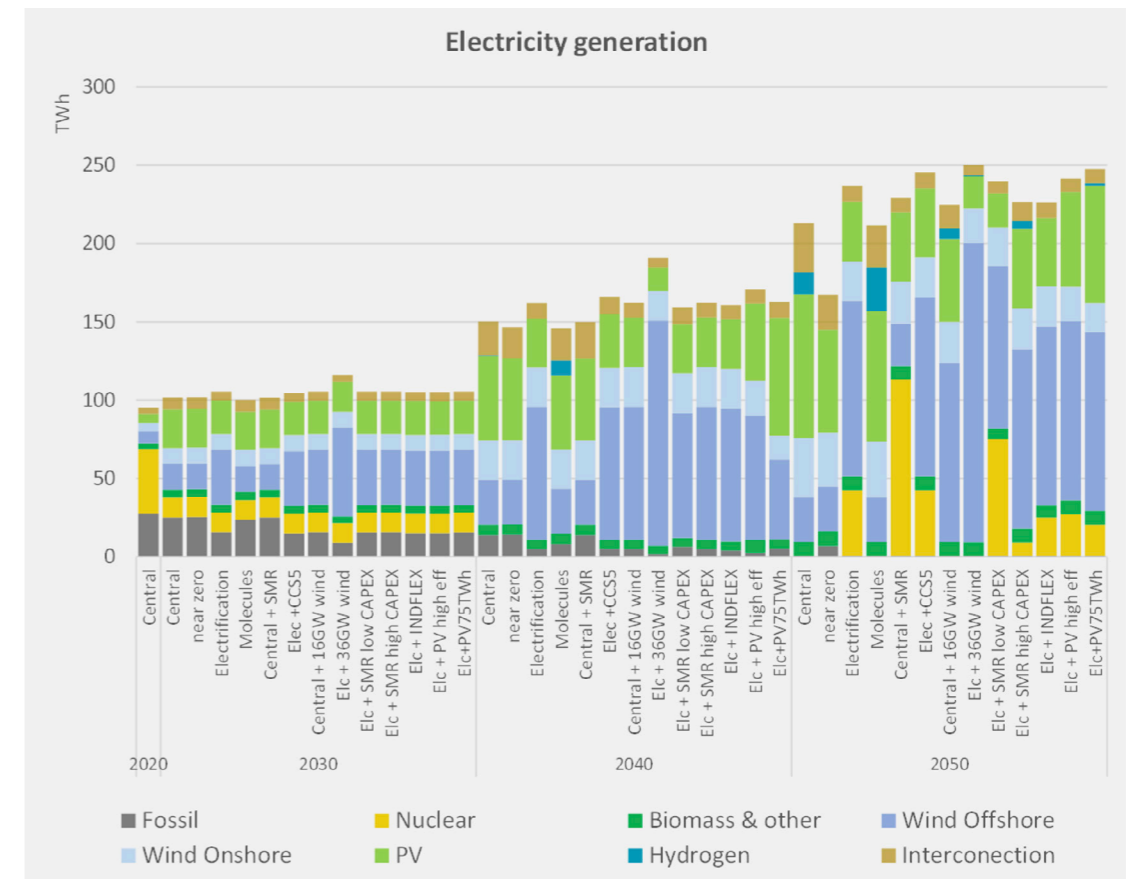

Figure 38. Power generation by technology in the three main scenarios (Central, Electrification, Clean Molecules) and six sensitivity cases (ten sensitivity model runs).

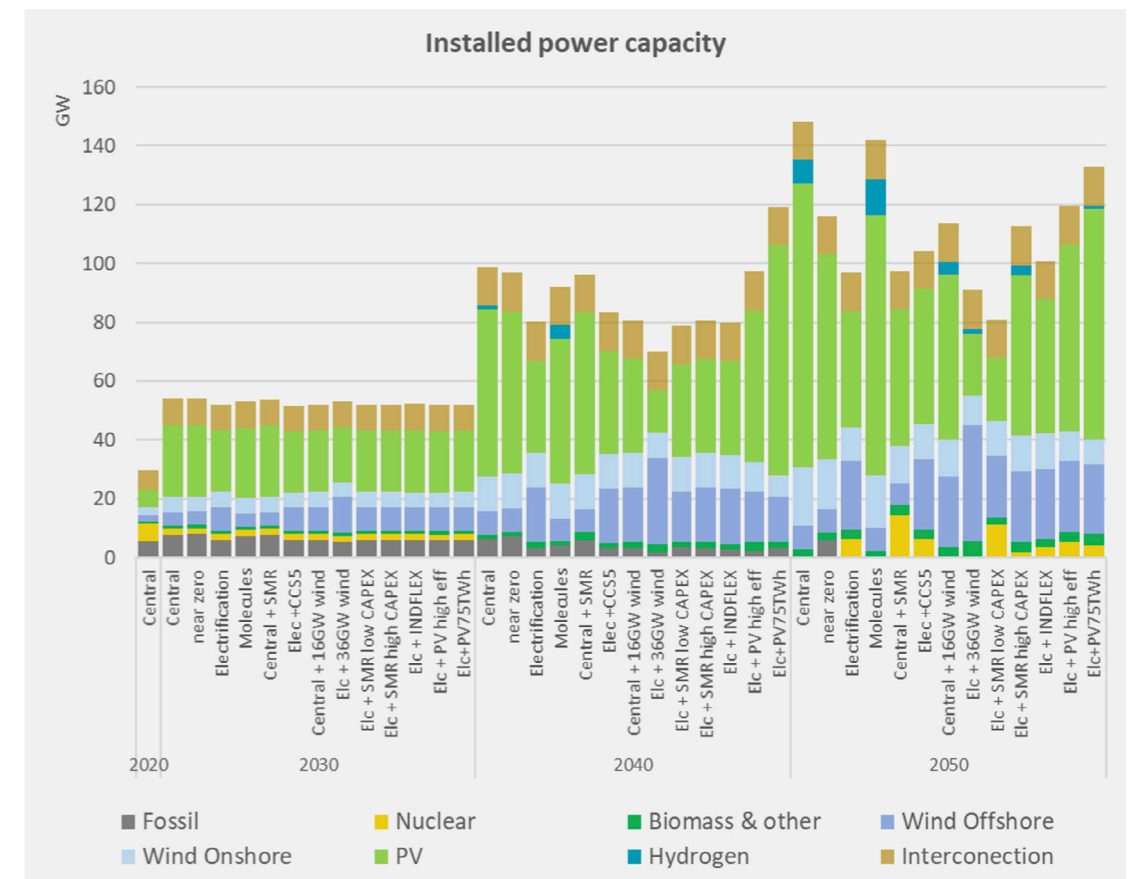

Figure 39. Installed power capacity by technology in the three main scenarios (Central, Electrification, Clean Molecules) and six sensitivity cases (ten sensitivity model runs).

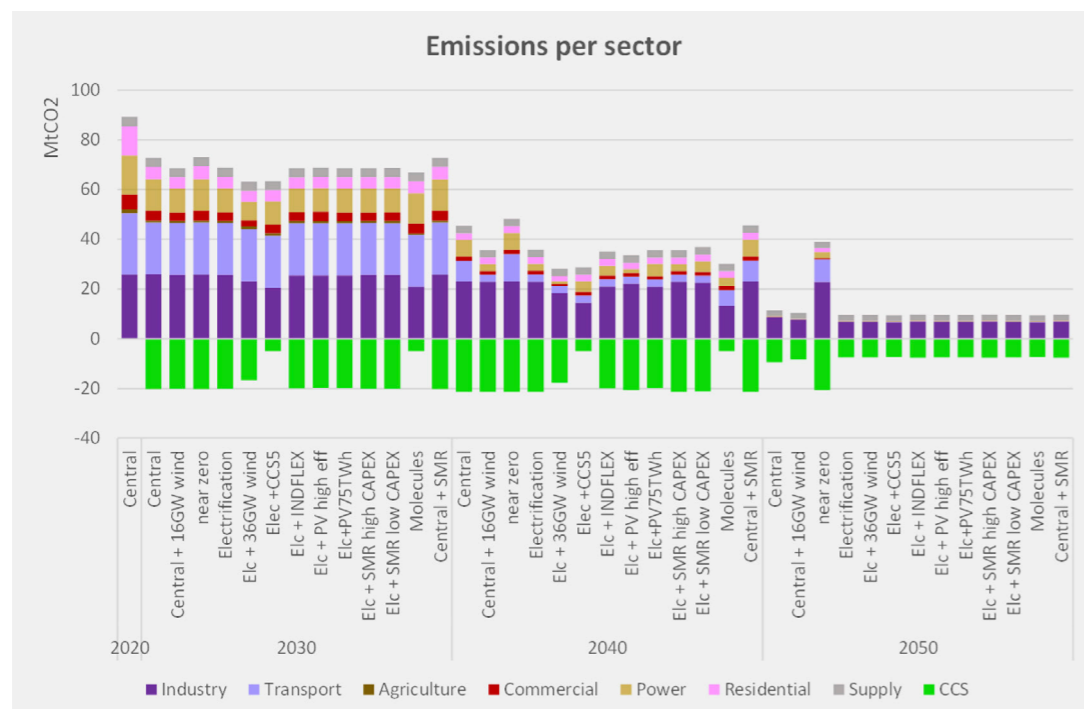

Figure 40. CO₂ emissions per sector and total CCS in the three main scenarios and six sensitivity cases (ten sensitivity model runs).

Offshore wind sensitivity case

Before 2040, access to additional zones for offshore wind is key, because it is the cheapest option to enable a fast electrification of the demand sectors. Under all model runs with additional 8 GW access, offshore wind capacity amounts to 8 GW by 2030, 12 GW by 2035 and between 15 and 19 GW by 2040. Additional offshore wind zones beyond the extra 16 GW have a smaller cost impact (Max offshore sensitivity case as stipulated in Table 22).

Starting from the 8 GW under the Central Scenario, offshore wind capacity reaches 24 GW (8 + 16) and 40 GW (8 + 32) in the sensitivity model runs by 2050. Adding more offshore wind power reduces mostly solar PV capacity and - linked to that - hydrogen-based capacity (see Figure 39). Compared to the Central Scenario, hydrogen-based electricity generation goes down from 14 to 0.7 TWh. Electricity imports reduce from 32 TWh under the Central Scenario to 15 TWh if 16 GW offshore wind is added, and to 6 TWh in the case of an additional 32 GW offshore wind.

These sensitivity cases show us that additional access to offshore wind is particularly interesting, as it can bring down the energy system costs and allow demand sectors to benefit from the additional electricity production. Especially the industry and transport sectors will face a large increase in electricity demand in the medium-term for electrifying their processes and vehicle fleet, including trucks. Therefore, there is only a limited timespan to push the development of offshore wind technologies. Indeed, for this phenomenon to materialise, low carbon electricity production - including all renewables and nuclear or other base load type of resources - should increase from its current production of about 65 TWh to 85 TWh by 2030, and to 150 TWh by 2040. Even more so, the electricity production from renewable resources should increase from its current production of about 22 TWh to 70 TWh by 2030, and 150 TWh by 2040. Thus, having access to additional offshore wind zones is vital.

The first additional 16 GW have a large impact on rendering the energy cost much cheaper. Nonetheless, going beyond that, the cost is not reduced that much. In the sensitivity case without new nuclear SMR, the additional offshore wind power mainly replaces solar PV. Conversely, in the sensitivity case in which new nuclear SMR is allowed, offshore wind replaces both solar PV and nuclear. With 40 GW of offshore wind capacity (Max offshore sensitivity case), the modelling results do not include investments in new nuclear (SMR). In all sensitivity cases, the additional offshore wind power reduces (other) electricity imports, as well as hydrogen-based electricity generation.

PV efficiency and cost sensitivity case

PV panels are deemed to be very cost-efficient in the years to come. After reaching 20% of electricity generation, the benefit from PV panels diminishes. With an increased efficiency of 50% (from 23% to 35%) - equivalent to a cost reduction of 33% - electricity generation from PV increases by 50%. When enforcing a high level of solar penetration in 2040, photovoltaic power starts to outcompete onshore wind power and the less favourable offshore wind parks. Increasing PV efficiency increases electricity generation from solar from nearly 40 TWh to 60 TWh in 2050. In the long term, PV capacity increases from 39 GW to 63 GW, which reduces the electricity generation from nuclear power plants.

Small Modular Reactor (SMR) sensitivity case

The SMR technology is always present if allowed, except if there is a total of 40 GW of offshore wind capacity. Allowing access to SMR in sensitivity cases increases the electricity demand by 5-9% due to the lower electricity price and lowers electricity imports. A 600 €/kWe investment cost reduction/increase leads to an increase/decrease of the SMR capacity by 1 GWe. The capacity factor of nuclear is above 75% under all scenarios, except in the sensitivity case with a lower investment cost (4500 €/kWe) where it reaches 64%.

In 2050, in the sensitivity case without additional offshore wind zones, nuclear power plants' capacity reaches 14 GWe and provides roughly half of the total electricity generation. Nuclear power plants mostly reduce the capacity of PV and hydrogen-based electricity generation. The lower the cost of the SMR, the more it produces, reducing the need to import molecules (H₂) to generate electricity during the evening and during some periods with low wind availability in the winter. Increasing the overnight capital cost from 7500 to 10500 €/kWe reduces the nuclear capacity from 6 GW to 1.5 GW. On the other hand, lowering the overnight capital cost from 7500 to 4500 €/kWe increases the nuclear capacity from 6 GWe to 11 GWe.

Industry flexibility sensitivity case

Allowing the TIMES-BE model to invest in additional production capacity for some key electrified industry processes provides an additional form of flexibility by 2050. We allowed the model to invest in additional electrified production capacity for:

- Chlorine production using the membrane cell process
- Steel production
- Electric arc furnaces
- Molten iron oxide electrolysis
- Copper production
- Zinc production
- Chemical sector: electrical cracking furnaces

The additional industrial flexibility can decrease the need for controllable load in a more cost-effective way. As a result, in comparison with the Electrification Scenario, the new nuclear SMR capacity decreases by 2.5 GW to 3.5 GW in 2050. Moreover, additional industrial flexibility decreases the need for controllable load more cost-effectively in certain periods. While the new nuclear capacity in 2050 is lower, the capacity of onshore and offshore wind is slightly higher. In 2050, the largest difference is the PV capacity, which increases by 6.4 GW to 45.9 GW when compared with the Electrification Scenario. The annual system costs of this sensitivity case are more than 1 billion euros lower than under the Electrification Scenario.

Carbon storage limitation sensitivity case

When CO₂ storage is limited to 5 million tons per year, net emissions increase by around 10 million tons in 2030. By 2050, there is an increased use of captured CO₂ for feedstock production (2 million tons per year) and increased electrification levels in the chemical sector. A limitation on the carbon storage potential to 5 Mton/y leads to a much slower CO₂ reduction trajectory. In the period 2030-2040, there is a lower overall emission reduction. This sensitivity case reaches a 52% reduction of emissions by 2030 (58 million tons of remaining emissions) and an 80% reduction by 2040 (24 million tons of remaining emissions). Capturing of CO₂ reaches a total of around 8 million tons per year in 2050. In the Carbon storage sensitivity case, 5 million tons go to the carbon storage and the remaining CO₂ are used for generating feedstocks (methanol synthesis).

In the medium-term, around 1 billion euros are saved every year by the reduced use of CCS technologies. The three most important savings are the reduced CO₂ storage costs, reduced investments in CO₂ capturing technologies and reduced energy losses inherent to the capturing process. However, the additional tax for the increased carbon emissions amounts to 1.5 billion euros every year. In the longer term - and with only 5 million tons of CO₂ storage - most of the storage is taken up by the cement sector, which indicates that this is a priority sector for CCS.

Near-zero emissions (85% reduction) sensitivity case

With a CO₂ price of 350 €/ton, CO₂ is reduced by 85% in 2050 (compared to 1990). The remaining 15% comes from sectors in which reducing all CO₂ is not cost-efficient if only this carbon price is applied, such as heavy-duty transport. This result is very sensitive to the assumption of maintenance cost. With a carbon price that reaches 250 €/ton in 2040, CO₂ is already reduced by 80%. In 2050, as residual emissions are incompatible with the concept of net zero, capturing of CO₂ is lower under the net zero scenarios than in the Near-zero sensitivity case. In the latter case, CCS reaches a level of 21 MtCO₂ per year.

The major difference with the net zero Central Scenario is that CCS remains prominent up to 2050. The residual emissions that cannot be captured are acceptable under a near-zero scenario, but are incompatible with the net zero emission concept.

Going from near-zero (-85%) to net zero can double the energy system costs beyond 2030. The additional cost is 2 billion euros in 2040, and 6 billion euros in 2050. Conversely, under the net zero scenario, no tax must be paid for the remaining 15% of emissions, amounting to 6 billion euros annually.

7.2 Annual costs by sensitivity case

Achieving deep decarbonization of the energy system involves various costs, as depicted in Figure 4.1. While some cases exhibit minimal differences in capital investment and operational cost, early decisions have a substantial impact on future investments. For instance, delaying the electrification of end uses turns investing in fossil-based technologies into a need during the transition period, rendering technology replacement towards 2050 more expensive.

The sensitivity analyses conducted in this study reveal that electrification is the preferred alternative. Therefore, timely access to clean electrons is more critical than the optimal mix. From Figure 4.1, it can be inferred that all scenarios with at least 15 GW offshore wind power by 2040 have similar total costs. In terms of cost efficiency during the 2030-2040 period, offshore wind is followed by onshore wind and solar electricity. However, if photovoltaic power is enforced in 2040 (Electr. PV 75% Push sensitivity model run), solar PV begins to outcompete onshore wind power and less favourable offshore wind parks.

The introduction of new nuclear SMRs has a significant impact on the electricity mix in 2050, mainly reducing PV and hydrogen needs, as well as on the associated capital cost and on the cost of importing molecules. However, investments in nuclear SMRs are outcompeted if Belgium manages to secure an additional 32 GW of offshore wind power, or if the cost of SMRs exceeds 10800 €/kW. Electrification of demand sectors is largely independent of the electricity mix, with the only observed effect being that high levels of solar power trigger heat storage with basic electric heaters.

Going from the Near-zero sensitivity case, which achieves an 85% reduction in 2050, to the net zero scenarios (all the other scenarios) can double the energy system costs beyond 2030 (See Figure 4.1). Furthermore, in the case of the Central and Clean Molecules Scenarios and Central + SMR model run, it is crucial to emphasize that the lack of additional sources of clean electricity in the short term significantly increases the annual system cost, particularly due to stranded assets.

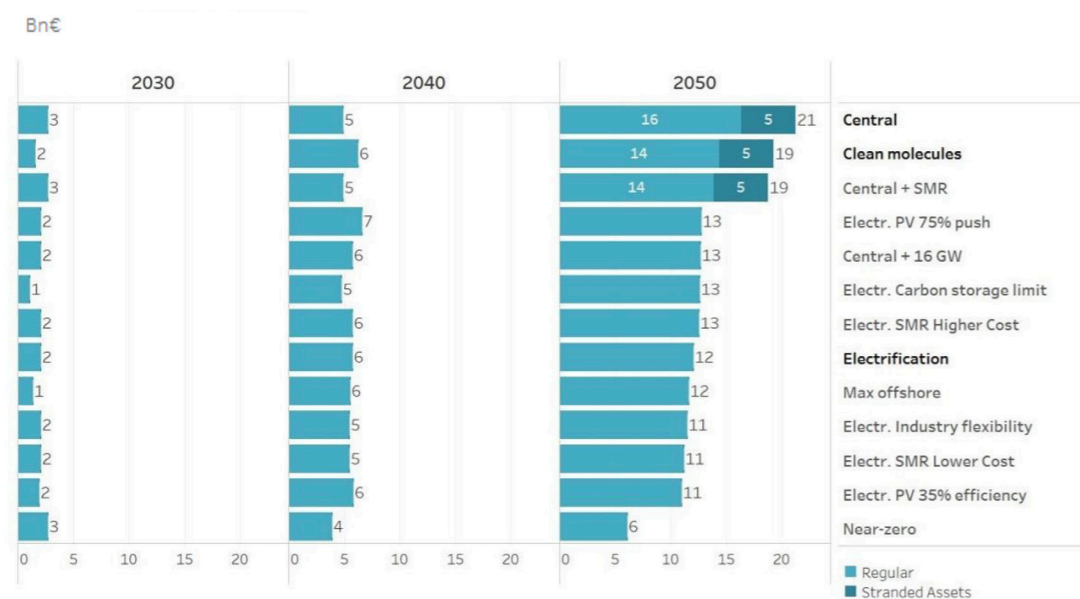

Figure 4.1. Annual system cost (CAPEX+OPEX) by scenario or sensitivity model run.

7.3 Key takeaways from sensitivity cases

The results of the sensitivity analysis reinforce the main findings of the study, confirming that a robust selection of basic scenarios was undertaken and that the key takeaways from the primary analysis remain unchanged for the demand sectors in 2030 and 2050. Further insights are provided regarding the challenges associated with fast electrification and the influence of technology assumptions and choices on costs.

Specifically, all scenarios - including the sensitivity cases and sensitivity model runs - necessitate a fourfold increase in solar PV capacity, and a twofold increase in onshore and offshore wind capacity by 2030. In all sensitivity analyses, it is expected that 1.5 million residential and commercial buildings will be equipped with heat pumps, and 2 million electric cars will be on the Belgian roads. By 2050, no fossil fuels will be utilised, except in limited quantities by some industries.

Low-carbon electricity is the primary resource for the total energy system, with no local green hydrogen production uptake before 2030. The Central and Clean Molecules Scenarios reveal a structural deficit of low-carbon resources. The period between 2030 and 2040 presents a significant challenge with regards to a structural deficit of low-carbon resources. The neighbouring countries' imports and the import capacity are inadequate, and importing molecules is expensive. Solar electricity is cost-effective, but its production profile does not align with the demand profile in some cases.

The lack of low-carbon electricity may prevent some demand sectors from electrifying and lead to them reinvesting in fossil-based technologies, resulting in a high risk of stranded assets. It is critical to have clean electrons available at the right time. While 2030 is an essential milestone, the period between 2030 and 2040 is crucial. The most cost-effective net zero emission scenario involves Belgium searching for renewable energy resources beyond its borders.

The electrification of demand can only occur on time if zero-carbon electricity reaches 70 TWh by 2030 and 150 TWh by 2040. Renewable energy production must triple by 2030 and increase sevenfold by 2040 from the current renewable electricity generation of 22 TWh. The most significant factor in reducing the energy system cost is access to additional offshore wind, as it enables early demand sector electrification. As such, around 19 GW of offshore wind will have to be operational by 2040, comprising 8 GW in Belgian waters and approximately 11 GW from additional sources.

Based on the study's assumptions, new small modular nuclear power plants (SMR) and offshore wind have comparable electricity costs. However, with our assumption that SMR will only be fully operational by 2050, it will come too late to ensure a smooth transition in the demand sectors. A significant portion of energy will therefore have to be imported from nearby sources, with less energy imported under all scenarios than in the present. By 2030, zero-carbon electricity is anticipated to reach 70 TWh under all scenarios, rising to 150 TWh by 2040 to facilitate timely demand electrification.

Conclusion and discussion

This PATHS 2050 study aims to provide cost-optimal transition pathways towards achieving an almost carbon-neutral Belgium by 2050. It is important to note that the scenarios developed in this study are not predictions of the future, but rather calculations based on a set of assumptions and projections. Our findings indicate that in the case of a net zero 2050, the electricity demand will more than double compared to 2020, while the final energy demand will decrease by a third, regardless of the scenario considered.

To achieve this ambitious goal, the fast deployment of renewable energy and related infrastructure is imperative. The study shows a need for at least 70 TWh of zero-carbon electricity by 2030, increasing to 150 TWh by 2040 under all scenarios. This can be reached by doubling onshore and offshore wind and quadrupling PV capacity compared to 2020, which is shown to be cost-effective regardless of the scenario choices.

Energy efficiency measures - such as renovation of the building stock - go hand in hand with the phasing out of fuel oil by 2030 and the natural gas distribution grid at a later stage, but well before 2050. Investments in the electricity distribution grid, heat pumps and heat networks are to replace current building heating systems.

In the transport sector, a fast adoption of battery electric passenger cars is crucial. Electrification of freight transport is shown to be cost-effective at later stages (beyond 2030), but highly dependent on the availability of enough zero-carbon electricity. The model results show that the use of hydrogen or e-fuels in the built environment and Belgian transport sector is not cost-effective.

An electricity system dominated by intermittent renewable production - more than 80% of the Belgian generation under all scenarios - requires access to abundant flexibility and a certain capacity of controllable load. Flexibility can be provided to the system in the form of short- and long-term storage and demand flexibility. The TIMES-BE model invests in short-term (day-night) battery storage - up to 19 GW - and Belgian hydrogen electrolyser capacity up to 13 GW under the Central Scenario. Investments in heat pumps with water buffers and smart charging stations for electric passenger cars (at least 1,1 million by 2050) are crucial to provide demand flexibility. E-fuel turbines - up to 8 GWe by 2050 under the Central Scenario - are providing controllable load during peak demand periods (less than 1.800 operating hours/year). Having access to 16 GW additional offshore wind capacity outside the Belgian borders and nuclear SMR at a later stage will halve the investments in Belgian onshore and PV capacity, and reduces the need for short-term battery storage (5,6 GWe by 2050) and e-fuel turbines.

The TIMES-BE model shows that Carbon Capture and Storage will be essential to achieve fast reductions in the industry and refinery sector by 2030. Up to 20 Mton of CO₂ emissions could be reduced in these sectors when the carbon price reaches 150 €/ton by 2030 and increases to 350 €/ton by 2050. At the same time, while this latter use of CCS in the industry will help realise fast CO₂ reductions by 2030, it alone cannot achieve the net zero ambition. Achieving net zero carbon emissions by 2050 will require additional efforts to adopt carbon-neutral technologies in all sectors. Thus, a switch to more electrification and the use of hydrogen (or derivatives) will be necessary for the industry to attain that net zero goal.

As such, from a technical and societal perspective, a climate-neutral scenario is not only feasible, but - in terms of cost - the energy transition is equally affordable. Depending on the scenario, additional annual costs of 11,7 to 21 billion euros - which is 2-4% of the gross domestic product (reference 2021) - could make Belgium climate-neutral, while maintaining its current industrial output compared to a scenario without stringent climate action. The early access to abundant zero-carbon electricity under the Electrification Scenario, with additional access to offshore wind outside Belgian borders and nuclear SMR by 2050, leads to the lowest additional societal system costs.

The next few years will thus be crucial, and preparatory work is necessary: even though our study shows that it is still possible to reach a carbon-neutral Belgium by 2050, in the immediate future there remains little room for manoeuvre.

The sensitivity analysis conducted to support the findings of this study on Belgium's energy transition to net zero emissions confirmed the study's main conclusions, including the need for a drastic increase in solar PV and onshore and offshore wind capacity by 2030. However, the sensitivity analysis also highlighted challenges associated with fast electrification, such as a deficit of low-carbon resources in the period between 2030 and 2040, which could lead to stranded assets and reinvestment in fossil-based technologies. Our study suggests that importing renewable energy from neighbouring countries and increasing offshore wind capacity beyond Belgian territory are key factors in reducing the energy system cost and enabling timely demand electrification. It also notes that nuclear SMRs have comparable costs to offshore wind. Having access to these technologies - to a large extent to be operational by 2040 already - will lower system costs and will ensure a smoother transition.

Thus, the results presented in this study provide insights into cost-effective pathways achieving climate neutrality in Belgium.

Nevertheless, it is important to note that the study did not address whether Belgian energy-intensive industries would be able to compete with countries having abundant cheap renewable energy sources, nor were the benefits of climate action - such as fewer natural disasters and a positive impact on air quality and health - quantified. Furthermore, it is worth noting that there are still other topics that are linked to the energy transition, which were not fully covered in the present study. For instance, the consideration of limitations due to critical material availability, which is something which will be worked out further in the Energy Transition Fund project [CIREC](#). The TIMES-BE model is able to capture cross-sector, cross-energy vector and cross-border flows of electricity and molecules, and provide investment pathways towards a carbon-neutral society in 2050. Therefore, improvements in representing molecule imports and exports and electricity flows in Europe will further be analysed in the Energy Transition Fund project [TRILATE](#).

In other words, to facilitate the necessary advancements in the field of the energy transition, it is imperative to continue investigating critical questions and expanding the scope of the TIMES-BE model in the coming years. This endeavour will require collaboration between various stakeholders - including, but not limited to, industry representatives, policymakers, energy modelling experts, infrastructure operators and energy and feedstock suppliers. By harnessing the expertise of these stakeholders, we can jointly generate valuable insights to secure informed decision-making processes. Additionally, updating the model to reflect the latest advancements in technology and the most pertinent discussions will help ensure the continued relevance and effectiveness of the TIMES-BE model.

This document described the main assumptions of the TIMES-BE model, which generated study results that are available in full detail on the online [PATHS 2050 Platform](#). The authors thank the Energy Transition Fund of the FPS Economy for funding the model developments, and FEBELIEC VZW for funding the scenario development and facilitating access to the Belgian industry sectors.

The opinions expressed in this publication are those of the authors.

Annex A. Main techno-economic assumptions

Discount rate: 3%

Electricity generation

Technology	CAPEX [€/kW]			FIXOM [€/kW]			VAROM no fuel [€/MWh]			Efficiency	Lifetime [yr.]	Source
	2030	2040	2050	2030	2040	2050	2030	2040	2050			
OCGT	568	568	568	19	19	19	-	-	-	42%	20	EnergyVille-Engie study ¹²²
CCGT	855	855	855	20	20	20	-	-	-	59%	30	
Biomass plant	2000	2000	2000	30	30	30	-	-	-	39%	40	
Gas CHPs	1180	1180	1180	45	45	45				32% ¹²³	30	
Bio CHPs	1000	1000	1000	50	50	50	-	-	-	14%	40	
Residential PV	600	480	360	25	25	25	-	-	-	n.a.	25	
Com/Ind PV	540	432	324	17	16	15	-	-	-	n.a.	25	
Onshore wind	965	851	737	42	40	37	-	-	-	n.a.	30	
Offshore wind	1750	1625	1500	65	57	50	-	-	-	n.a.	30	
North Sea wind	2700	2575	2450	65	57	50	-	-	-	n.a.	30	
H ₂ turbine	568	568	568	19	19	19	-	-	-	43%	20	
Nuclear SMR	7500	7500	7500	83	83	83	7.5	7.5	7.5	33%	60	

Power grid reinforcements

Infrastructure	CAPEX [€/kW]	Losses	Lifetime [yr]
Distribution grid	4320	3.2%	50
Transmission grid	-	2.7%	50

Molecules

Technology	CAPEX [€/kW]			OPEX [€/kW]			Efficiency			Lifetime [yr.]	Source
	2030	2040	2050	2030	2040	2050	2030	2040	2050		
Alkaline Electrolyser, large size	327	285	243	4	3	3	69%	72%	74%	20	[2], [7], [8], [9], [10], [11], [12]
PEM Electrolyser, large size	653	463	274	10	7	4	69%	72%	74%	20	[2], [7], [9], [10], [11], [12]
SOE Electrolyser, medium size	1,421	1,011	600	36	38	39	32%	41%	58%	20	[7], [9], [11]
Biomass Gasification	1,291	1,291	1,291	65	65	65	34%	34%	34%	20	[4]
Methane Steam Reforming	841	841	841	40	40	40	76%	76%	76%	20	[5]
Methane Steam Reforming + Carbon Capture	1,360	1,320	1,280	50	50	50	67%	67%	67%	20	[5]
Pyrolysis Reactor	689	454	218	17	17	17	48%	48%	48%	20	[6]
Pyrolysis Plasma	2,303	712	85	52	52	52	52%	52%	52%	20	[6]

Reference	Source
1	Study IndWEde – Brief Overview, NOW, 2018.; https://www.now-gmbh.de/wp-content/uploads/2020/09/181204_bro_a4_indwede-studie_kurzfassung_en_v03-1.pdf
2	Hydrogen Economy Outlook, BNEF, 2020.; https://data.bloomberglp.com/professional/sites/24/BNEF-Hydrogen-Economy-Outlook-Key-Messages-30-Mar-2020.pdf
3	EUREF2020 – Technology Assumptions Energy; https://energy.ec.europa.eu/data-and-analysis/energy-modelling/eu-reference-scenario-2020_en
4	How far away is hydrogen? Its role in the medium and long-term decarbonisation of the European energy system. Alessandra Sgobbi, et al. 2016.; http://dx.doi.org/10.1016/j.ijhydene.2015.09.004
5	IEA G20 Hydrogen report: Assumptions, 2019.; https://www.iea.org/reports/the-future-of-hydrogen/data-and-assumptions
6	Hydrogen and hydrogen-derived fuels through methane decomposition of natural gas – GHG emissions and costs. Timmerberg S, et al. 2020; https://doi.org/10.1016/j.ecmx.2020.100043
7	GREEN HYDROGEN COST REDUCTION, IRENA, 2020.; https://www.irena.org/-/media/Files/IRENA/Agency/Publication/2020/Dec/IRENA_Green_hydrogen_cost_2020.pdf
8	EU-wide innovation support is key to the success of electrolysis manufacturing in Europe, AGORA, 2019.; https://www.agora-energiende.de/fileadmin/Blog/2019/Electrolysis_manufacturing_Europe/2019-11-08_Background_paper_Hydrogen_cost.pdf
9	Fueling the future of mobility: hydrogen electrolyzers, Deloitte, 2021; https://www2.deloitte.com/content/dam/Deloitte/jp/Documents/global-business-support/jp-gbs-fueling-the-future-of-mobility-hydrogen-electrolyzers.pdf
10	Projecting the future cost of PEM and alkaline water electrolyzers, Anita H., et al, 2022; https://doi.org/10.1016/j.ijhydene.2022.08.306
11	Cost-competitive green hydrogen, Oxford-IES, 2022.; https://www.oxfordenergy.org/wpcms/wp-content/uploads/2022/01/Cost-competitive-green-hydrogen-how-to-lower-the-cost-of-electrolyzers-EL47.pdf
12	A One-GigaWatt Green-Hydrogen Plant, ISPT, 2022.; https://ispt.eu/media/Public-report-gigawatt-advanced-green-electrolyser-design.pdf

Carbon capture technologies

Technology	CAPEX [€/t]			OPEX [€/t]			Capture Efficiency	Lifetime [yr.]	Reference
	2030	2040	2050	2030	2040	2050			
DAC	1,140	1,140	1,140	200	200	200	100%	25	[1]
Steel CC unit amine-based	397	397	397	14	14	14	75%	25	[2],[3]
Steel CC unit amine-based	411	411	411	14	14	14	75%	25	[2],[3], *
Chemicals CC unit amine-based	36	36	36	1	1	1	90%	25	[2],[3]
Chemicals CC unit amine-based	50	50	50	2	2	2	90%	25	[2],[3], *
Cement CC unit amine-based	650	650	650	22	22	22	85%	25	[2],[3]
Cement CC MEA	129	129	129	4	4	4	85%	25	[4]
Cement CC MEA	152	152	152	5	5	5	85%	25	[4], *
Cement CC Oxyfuel	168	168	168	6	6	6	90%	25	[4]
Ceramics CC MEA	241	241	241	8	8	8	85%	25	[5]
Ceramics CC MEA	256	256	256	9	9	9	85%	25	[5], *
Glass CC MEA	348	348	348	12	12	12	85%	25	[6]
Glass CC MEA	356	356	356	12	12	12	85%	25	[6], *
Refineries CC MEA	216	216	216	9	9	9	90%	25	[3], [7], [8]
Refineries CC MEA	232	232	232	9	9	9	90%	25	[3], [7], [8], *

Reference	Source
1	The role of Direct Air Capture and Carbon Dioxide Removal in Well below 2°C scenarios in ETSAP-TIAMEPMG-UCC, 2018; https://www.iea-etsap.org/workshop/gothenburgh_june2018/28-Glynn_ETSAP2018.pdf
2	Technology Data: Carbon capture, transport and storage, Danish energy Agency, 2021.; https://ens.dk/sites/ens.dk/files/Analyser/technology_data_for_carbon_capture_transport_and_storage.pdf
3	TECHNOLOGY READINESS AND COSTS OF CCS, Global CCS institute, 2021.; https://www.globalccsinstitute.com/wp-content/uploads/2021/04/CCS-Tech-and-Costs.pdf
4	Gardarsdottir, S.O.; et al. Comparison of Technologies for CO2 Capture from Cement Production—Part 2: Cost Analysis. Energies 2019.; https://doi.org/10.3390/en12030542
5	Decarbonisation Options For The Dutch Ceramic Industry, TNO, 2020.; https://www.pbl.nl/sites/default/files/downloads/pbl-2020-decarbonisation-options-for-the-dutch-ceramic-industry_4544.pdf
6	DRAX demonstration project, 2019; https://www.thechemicalengineer.com/features/capturing-co2-with-c-capture/
7	CARBON CAPTURE WITH LEAST OPEX AND CAPEX, PTQ, 2021.; https://www.alfalaval.com/globalassets/documents/industries/energy/crude-oil-refinery/application-leaflets/carbon-capture-with-least-opex-and-capex.pdf
8	The potential for application of CO2 capture and storage in EU oil refineries, CONCAWE, 2011.; https://www.concawe.eu/wp-content/uploads/2017/01/rpt_11-7-2011-03321-01-e.pdf
*	(heat source assumed to be electrifiable)



PATHS 2050



Empowered by KU Leuven, VITO, imec & UHasselt